

CLASS GUIDELINE

DNVGL-CG-0127

Edition October 2015

Finite element analysis



FOREWORD

DNV GL class guidelines contain methods, technical requirements, principles and acceptance criteria related to classed objects as referred to from the rules.

© DNV GL AS

Any comments may be sent by e-mail to rules@dnvgl.com

If any person suffers loss or damage which is proved to have been caused by any negligent act or omission of DNV GL, then DNV GL shall pay compensation to such person for his proved direct loss or damage. However, the compensation shall not exceed an amount equal to ten times the fee charged for the service in question, provided that the maximum compensation shall never exceed USD 2 million.

In this provision "DNV GL" shall mean DNV GL AS, its direct and indirect owners as well as all its affiliates, subsidiaries, directors, officers, employees, agents and any other acting on behalf of DNV GL.

CHANGES – CURRENT

This is a new document.

CONTENTS

Changes – current.....	3
Section 1 Finite element analysis.....	7
1 Introduction.....	7
1.1 General.....	7
1.2 Objective of Class Guideline.....	7
1.3 Calculation methods.....	7
1.4 Material properties.....	7
1.5 Global coordinate system.....	8
1.6 Corrosion Deduction.....	8
1.7 Finite element types.....	9
1.8 Singularities in membrane elements.....	10
1.9 Model check.....	10
2 Documentation.....	11
2.1 Reporting.....	11
Section 2 Global strength analysis.....	12
1 Objective and scope.....	12
2 Global structural FE model.....	12
2.1 General.....	12
2.2 Model extent.....	12
2.3 Mesh arrangement.....	14
2.4 Model idealisation.....	16
2.5 Boundary conditions.....	20
3 Load application for global FE analysis.....	22
3.1 General.....	22
4 Analysis Criteria.....	22
4.1 General.....	22
4.2 Yield strength assessment.....	22
4.3 Buckling strength assessment.....	23
4.4 Fatigue strength assessment.....	23
Section 3 Partial ship structural analysis.....	24
1 Objective and scope.....	24
1.1 General.....	24
1.2 Application.....	24

1.3 Definitions.....	25
1.4 Procedure of cargo hold analysis.....	26
1.5 Scantlings assessment.....	26
2 Structural model.....	27
2.1 Extent of model.....	27
2.2 Structural modelling.....	30
3 Boundary conditions.....	39
3.1 General.....	39
3.2 Boundary conditions in cargo hold analysis.....	40
4 FE load combinations and load application.....	42
4.1 Sign convention.....	42
4.2 Design rule loads.....	42
4.3 Rule FE load combinations.....	42
4.4 Principles of FE load combinations.....	43
4.5 Load application.....	44
5 Internal and external loads.....	44
5.1 Pressure application on FE element.....	44
5.2 External pressure.....	44
5.3 Internal pressure.....	45
5.4 Other loads.....	45
6 Hull girder loads.....	45
6.1 General.....	45
6.2 Hull girder targets.....	45
6.3 Procedure to adjust hull girder shear forces and bending moments.....	48
6.4 Procedure to adjust hull girder torsional moments.....	63
6.5 Summary of hull girder load adjustments.....	65
7 Analysis criteria.....	66
7.1 General.....	66
7.2 Yield strength assessment.....	67
7.3 Buckling strength assessment.....	68
Section 4 Local structure strength analysis.....	69
1 Objective and Scope.....	69
1.1 General.....	69
1.2 Modelling of standard structural details.....	69
2 Structural modelling.....	69
2.1 General.....	69
2.2 Fine mesh zone.....	70
2.3 FE model for fatigue strength assessments.....	73

3 Screening.....	74
3.1 General.....	74
3.2 Selection of structural detail for fine mesh analysis.....	74
3.3 Screening based on fine mesh analysis.....	74
4 Loads and boundary conditions.....	75
4.1 Loads.....	75
4.2 Boundary conditions.....	75
5 Analysis criteria.....	75
5.1 Reference stress.....	75
5.2 Permissible stress.....	76
5.3 Acceptance criteria - fine mesh permissible yield utilisation factors.....	76
Section 5 Beam analysis.....	77
1 Introduction.....	77
1.1 General.....	77
1.2 Application.....	77
1.3 Model types.....	77
2 Model properties.....	78
2.1 General.....	78
2.2 Beam elements.....	78
2.3 Springs.....	83

SECTION 1 FINITE ELEMENT ANALYSIS

1 Introduction

1.1 General

This Class Guideline describes the scope and methods required for structural analysis of ships and the background for how such analyses should be carried out. The Class Guidelines application is based on relevant Rules for Classification of Ships.

The DNV GL Rules for Classification of Ships may require direct structural strength analyses as given in the rules.

Structural analyses carried out in accordance with the procedure outlined in this Class Guideline will normally be accepted as basis for plan approval.

Where the text refers to the Rules for Classification of Ships, the references refer to the latest edition of the Rules for Classification of Ships.

In case of ambiguity between the rules and the Class Guideline, the rules shall be applied.

Any recognised finite element software may be utilised provided that all specifications on mesh size, element type, boundary conditions etc. can be achieved with this computer program.

If wave loads are calculated from a hydrodynamic analysis, it is required to use recognised software. As recognised software is considered all wave load programs that can show results to the satisfaction of DNV GL.

1.2 Objective of Class Guideline

The objective of this Class Guideline is:

- To give a guidance for finite element analyses and assessment of ship hull structures in accordance with the Rules for Classification of Ships.
- To give a general description of relevant finite element analyses.
- To achieve a reliable design by adopting rational analysis procedures.

1.3 Calculation methods

The Class Guideline provides descriptions for three levels of finite element analyses:

- a) Global direct strength analysis to assess the overall hull girder response, given in [Sec.2](#).
- b) Partial ship structural analysis to assess the strength of hull girder structural members, primary supporting structural members and bulkheads, given in [Sec.3](#).
- c) Local structure analysis to assess detailed stress levels in local structural details, given in [Sec.4](#).

The Class Guideline, DNVGL-CG-0129 *Fatigue assessment of ship structures*, describes methods of local finite element analyses for fatigue assessment.

[Sec.5](#) provides descriptions for a 2 and 3 dimension beam analyses of ship structures.

1.4 Material properties

Standard material properties are given in [Table 1](#).

Table 1 Material properties

	Young's Modulus [kN/m ²]	Poisson Value	Shear Modulus [kN/m ²]	Density [t/m ³]
Steel	$2.06 \cdot 10^8$	0.30	$0.792 \cdot 10^8$	7.80
Alu	$0.70 \cdot 10^8$	0.33	$0.263 \cdot 10^8$	2.75

The minimum yield stress R_{eH} has to be related to the material defined as indicated in the rules, [RU SHIP Pt.3 Ch.3 Sec.1 Table 1](#). Consequently, it is recommended that every steel grade is represented by a separate material data set in the model, as the materials are defined in the structural drawings.

1.5 Global coordinate system

The following co-ordinate system is recommended; right hand co-ordinate system, with the x-axis positive forward, y-axis positive to port and z-axis positive vertically from baseline to deck. The origin should be located at the intersection between aft perpendicular (AP), baseline and centreline. The co-ordinate system is illustrated in [Figure 1](#).

It should be noted that loads according to the rules, [RU SHIP Pt.3 Ch.4](#) refer to a coordinate system with a different x-origin (located at aft end (AE) of the rule length L). This coordinate system is defined in the rules, [RU SHIP Pt.3 Ch.1 Sec.4 \[3.6.1\]](#).

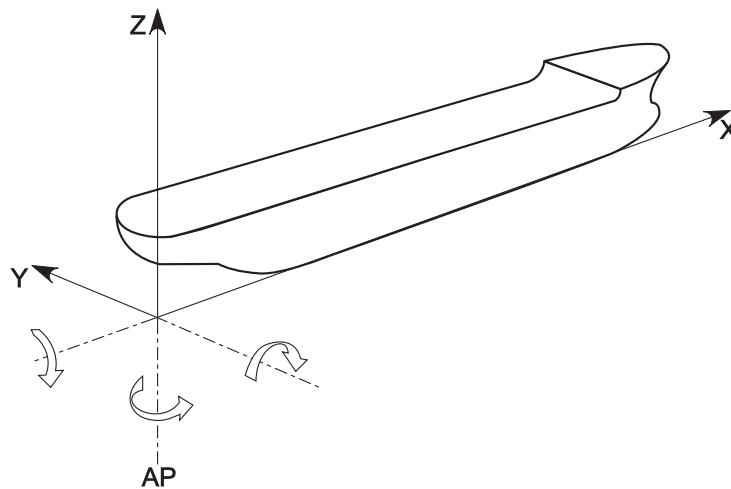
**Figure 1 Global coordinate system**

1.6 Corrosion Deduction

FE models are to be based on the scantlings with the corrosion deductions according to the rules, [RU SHIP Pt.3 Ch.3 Sec.2 Table 1](#), as follows

- 50% corrosion deduction for ships with class notation ESP;
- 0% corrosion deduction for other ships.

Buckling capacity assessment based on FE analysis is to be carried out with 100% corrosion deduction.

1.7 Finite element types

All calculation methods described in this Class Guideline are based on linear finite element analysis of three dimensional structural models. The general types of finite elements to be used in the finite element analysis are given in [Table 2](#).

Table 2 Types of finite element

<i>Type of finite element</i>	<i>Description</i>
Rod (or truss) element	Line element with axial stiffness only and constant cross sectional area along the length of the element.
Beam element	Line element with axial, torsional and bi-directional shear and bending stiffness and with constant properties along the length of the element.
Shell (or plate) element	Surface element with in-plane stiffness and out-of-plane bending stiffness with constant thickness.
Membrane (or plane-stress) element	Surface element with bi-axial and in-plane plate element stiffness with constant thickness

2 node line elements and 4/3 node plate/shell elements are considered sufficient for the representation of the hull structure. The mesh descriptions given in this Class Guideline are based on the assumption that these elements are used in the finite element models. However, higher order elements may also be used.

Plate/shell elements with inner angles below 45 deg or above 135 deg between edges should be avoided.

Elements with high aspect ratio as well as distorted elements should be avoided. Where possible, the aspect ratio of plate/shell elements is to be kept close to 1, but should not exceed 3 for 4 node elements and 5 for 8 node elements.

The use of triangular shell elements is to be kept to a minimum. Where possible, the aspect ratio of shell elements in areas where there are likely to be high stresses or a high stress gradient, is to be kept close to 1 and the use of triangular elements is to be avoided.

In case of linear elements (4/3 node elements) it is necessary that the plane stress or shell/plate element's shape functions include "incompatible modes" which offer improved bending behaviour of the modelled member, as illustrated in [Figure 2](#). This type of element is required particularly for the modelling of web plates in order to calculate the bending stress distribution correctly with a single element over the full web height. For global FE-models, the mesh description given in this Class Guideline is based on the assumption that elements with "incompatible modes" are used.

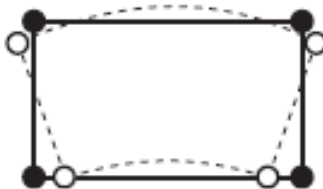

Figure 2 Improved bending of web modelled with one element over height

For the global, partial ship and fine mesh strength analyses, the assessment against stress acceptance criteria is normally based on membrane (or in-plane) stresses of shell/plate elements. For the fatigue assessment, the calculation of dynamic stress range for the determination of fatigue life is based on surface stresses of shell/plate elements.

1.8 Singularities in membrane elements

For global FE analysis translatory singularities in membrane elements structures can be avoided by arranging so-called singularity trusses as indicated in Figure 3. To avoid any load transfer by these trusses, load application on the singularity nodes in the weak direction is to be suppressed. Some FE programs suppress these singularities internally.

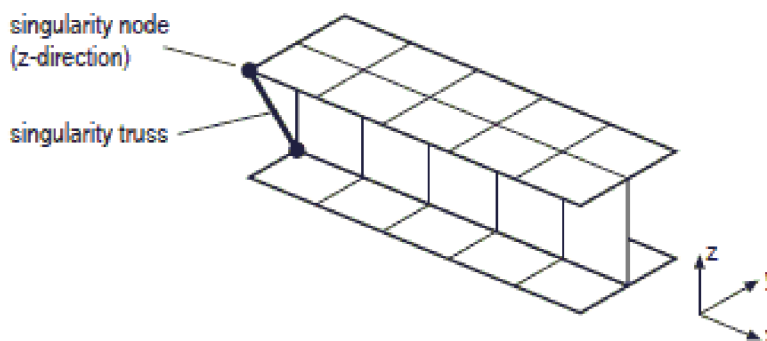

Figure 3 Singularity trusses

1.9 Model check

The FE model shall be checked systematically for the following possible errors:

- fixed nodes
- nodes without stiffness
- intermediate nodes on element edges not connected to the element
- trusses or beams crossing shells
- double elements
- extreme element shapes (element edge aspect ratio and warped elements)
- incorrect boundary conditions

Additionally, verification of the correct material and geometric description of all elements is required. Also, moments of inertia, section moduli and neutral axes of the complete cross sections shall be checked.

To check boundary conditions and detect weak areas as well as singular subsystems, a test calculation run is to be performed. The model should be loaded with a unit force at all nodes or gravity loads for each coordinate direction. This will result in three load cases – one for each direction. The calculated results have to be checked against maximum deformations in all directions and regarding plausibility of the boundary conditions. This test helps to find areas of improper connections between adjacent elements or gaps between elements. Substructures can be detected as well.

Test calculation runs are to be performed to check whether the used auxiliary systems can move freely without restraints from the hull stiffness.

2 Documentation

2.1 Reporting

A detailed report, paper or electronic, of the structural analysis is to be submitted by the designer/builder to demonstrate compliance with the specified structural design criteria. This report shall include the following information:

- a) Conclusions
- b) Results overview, including:
 - Identification of structures with the highest stress/utilisation levels
 - Identification of load cases in which the highest stress/utilisation levels occur
- c) List of plans (drawings, loading manual etc.) used including dates and versions.
- d) List of used Units
- e) Discretisation and range of model (eccentricity of beams, efficiency of curved flanges, assumptions, representations and simplifications)
- f) Detailed description of structural modelling including all modelling assumptions, element types, mesh size and any deviations in geometry and arrangement of structure compared with plans.
- g) Plot of complete model in 3D-view
- h) Plots to demonstrate correct structural modelling and assigned properties.
- i) Details of material properties, plate thickness (color plots), beam properties used in the model.
- j) Details of boundary conditions.
- k) Details of all load combinations reviewed with calculated hull girder shear force, bending moment and torsional moment distributions.
- l) Details of applied loads and confirmation that individual and total applied loads are correct.
- m) Details of reactions in boundary conditions.
- n) Plots and results that demonstrate the correct behaviour of the structural model under the applied loads.
- o) Summaries and plots of global and local deflections.
- p) Summaries and sufficient plots of stresses to demonstrate that the design criteria are not exceeded in any member. Results presented as colour plots for:
 - Shear stresses
 - In plane stresses
 - Equivalent (von-Mises) stresses
 - Axial stress (beam, trusses)
- q) Plate and stiffened panel buckling analysis and results.
- r) Tabulated results showing compliance, or otherwise, with the design criteria.
- s) Proposed amendments to structure where necessary, including revised assessment of stresses, buckling and fatigue properties showing compliance with design criteria.
- t) Reference of the finite element computer program, including its version and date.

SECTION 2 GLOBAL STRENGTH ANALYSIS

1 Objective and scope

This section provides guidelines for global FE model as required in the rules, [RU SHIP Pt.3 Ch.7 Sec.2](#), including the hull structure idealizations and applicable boundary conditions. For some specific ship types additional modelling descriptions are given in the rules [RU SHIP Pt.5](#) and corresponding Class Guidelines.

The objective of the global strength analysis is to calculate and assess the global stresses and deformations of hull girder members.

The global analysis is addressed to ships where the hull girder response cannot be sufficiently determined by using beam theory. Normally, the global analysis is required for ships:

- with large deck openings subjected to overall torsional deformation and stress response, e.g. Container vessels;
- without or with limited transverse bulkhead structures over the vessel length, e.g. Ro-Ro vessels and car carriers;
- with partly effective superstructure and/ or partly effective upper part of hull girder, e.g. large cruise vessels ($L > 150$ m);
- with novel designs;
- if required by the rules (e.g. CSA and RSD Class notation)

The global analysis is generally based on load combinations that are representative with respect to the responses and investigated failure modes, e.g.: yield, buckling and fatigue. Depending on the ship shape and applicable ship type notation, different load concepts are used for the global strength analysis, as given in the rules, [RU SHIP Pt.5](#).

The analysis procedures such as model balancing, load applications, result evaluations are given separately in the rules, [RU SHIP Pt.5](#) and corresponding Class Guidelines for different ships types.

2 Global structural FE model

2.1 General

The global model is to represent the global stiffness satisfactorily with respect to the objective for the analysis.

The global model is used to calculate nominal global stresses in primary members away from areas with stress concentrations. In areas where local stresses are to be assessed, the global model provides deformations used as boundary conditions for local models (sub-modelling technique). In order to achieve this, the global FE-model has to provide a reliable description of the overall stiffness of the primary members in the hull.

Typical global finite element models are shown in [Figure 1](#) to [Figure 3](#).

2.2 Model extent

The entire ship shall be modelled including all structural elements. Both port and starboard side need to be included in the global model. All main longitudinal and transverse structure of the hull shall be modelled. Structures not contributing to the global strength and have no influence on stresses in the evaluation area of the vessel may be disregarded. The mass of disregarded elements shall be included in the model. Superstructure can be omitted, but is recommended to be included in order to represent its mass.

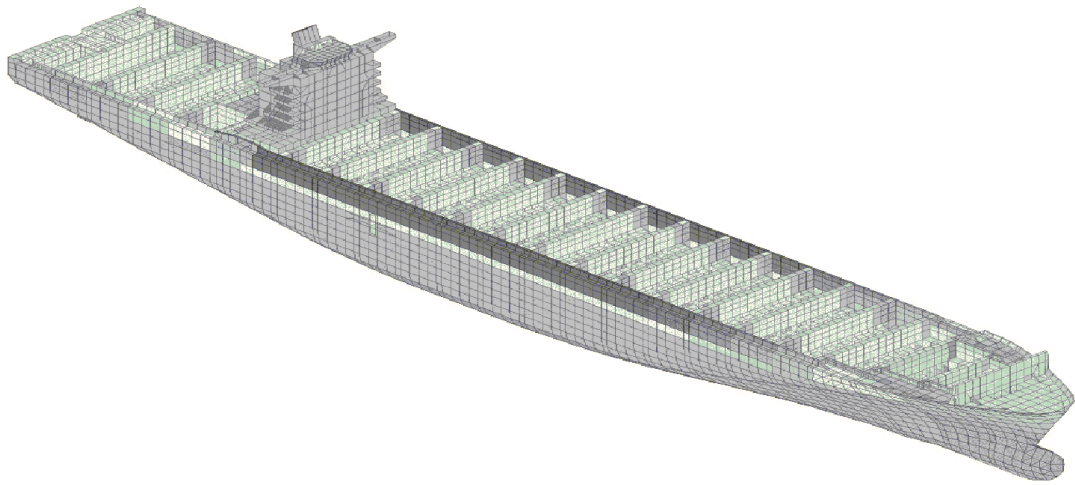

Figure 1 Typical global finite element model of a container carrier

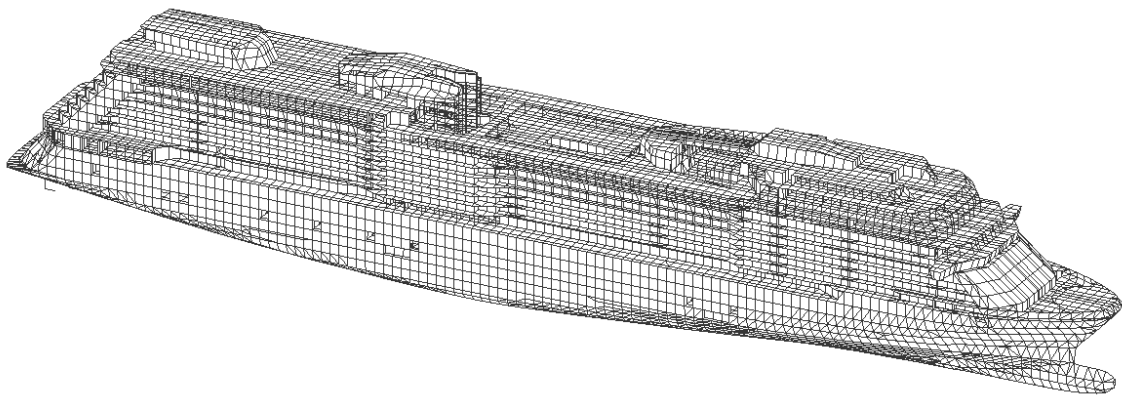

Figure 2 Typical global finite element model of a cruise vessel

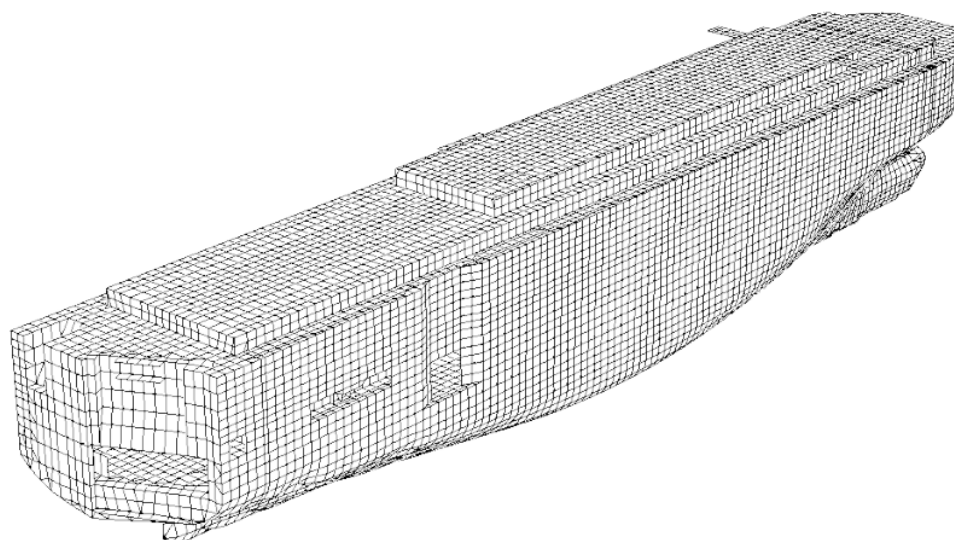

Figure 3 Typical global finite element model of a car carrier

2.3 Mesh arrangement

2.3.1 Standard mesh size for global FE model

The mesh size should be decided considering proper stiffness representation and load distribution. The standard mesh arrangement is normally to be such that the grid points are located at the intersection of primary members. In general, the element size may be taken as one element between longitudinal girders, one element between transverse webs, and one element between stringers and decks. If the spacing of primary members deviates much from the standard configuration, the mesh arrangement described above should be reconsidered to provide a proper aspect ratio of the elements and proper mesh arrangement of the model. The deckhouse and forecastle should be modelled using a similar mesh idealisation, including primary structures.

Local stiffeners should be lumped to neighbouring nodes, see [2.4.4].

Surface elements in inclined or curved surfaces shall be positioned at the geometrical centre of the modelled area if possible, in order that the global stiffness behaviour can be reflected as correctly as possible.

2.3.2 Finer mesh in global FE model

Global analysis can be carried out with finer mesh for entire model or for selected areas. The finer mesh model may be included as part of the global model as illustrated in Figure 4, or run separately with prescribed boundary deformations or boundary forces from the global model.

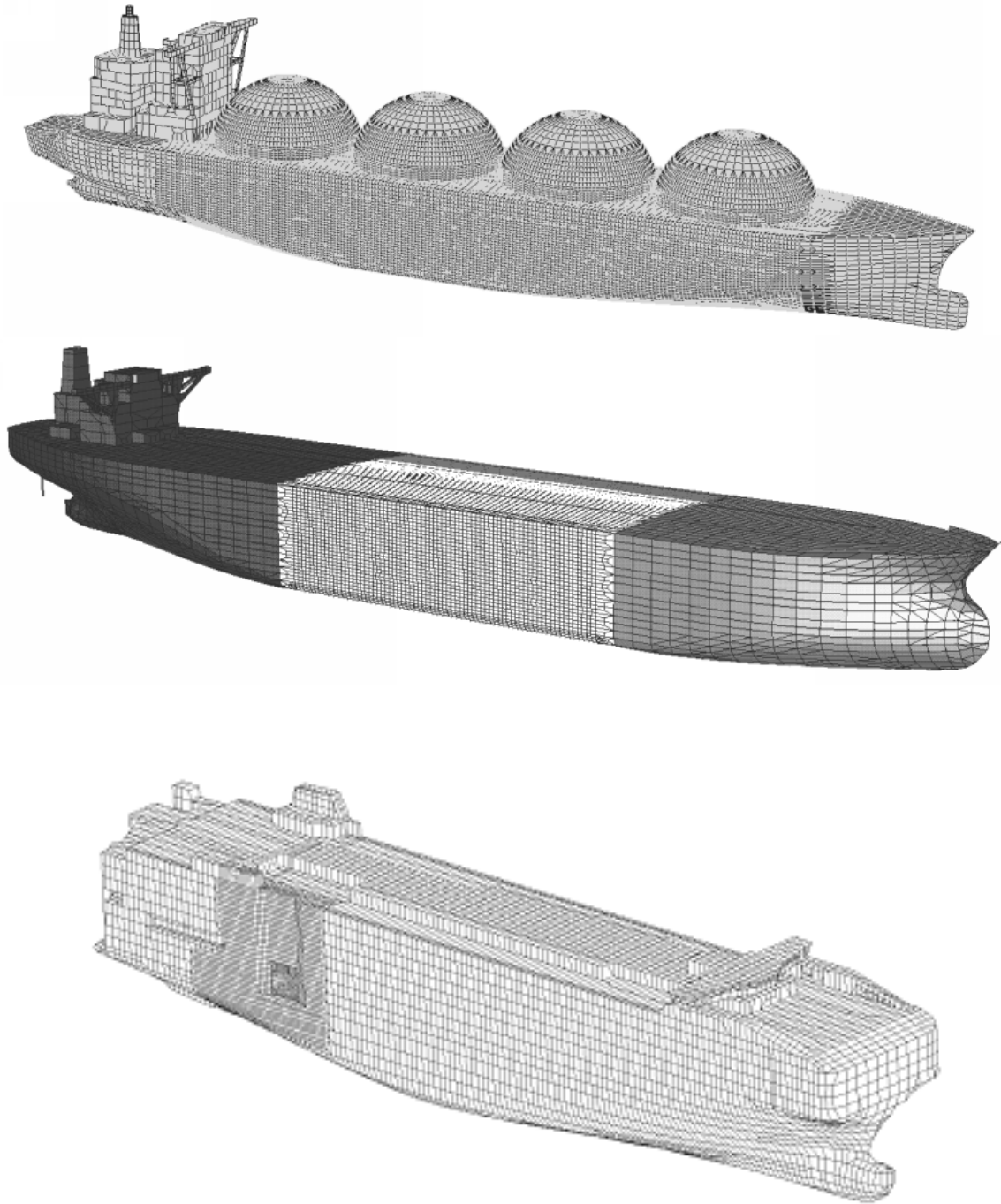

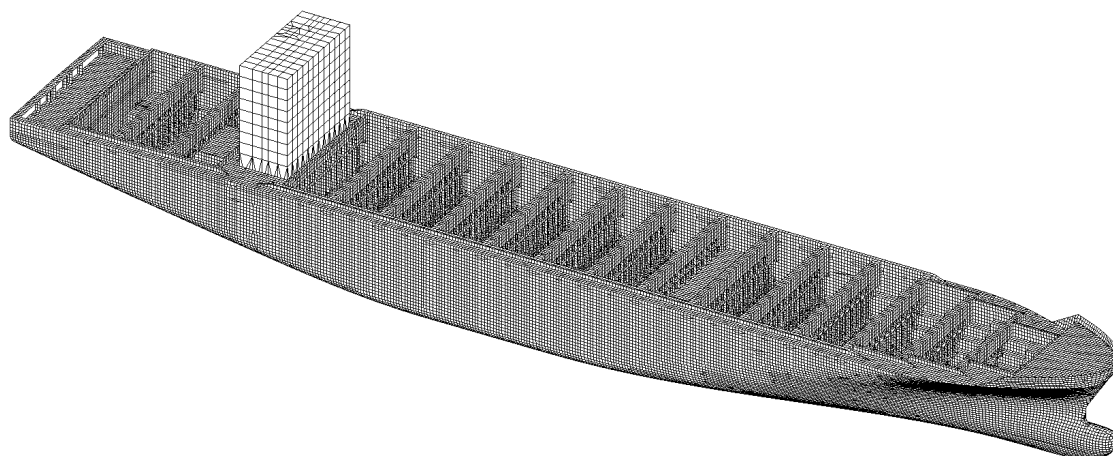

Figure 4 Global model with stiffener spacing mesh in cargo region/midship/ramp opening or within entire model extent

2.4 Model idealisation

2.4.1 General

All primary longitudinal and transverse structural members, i.e. shell plates, deck plates, bulkhead plates, stringers and girders and transverse webs, should in general be modelled by shell or membrane elements. The omission of minor structures may be accepted on the condition that the omission does not significantly change the deflection of structure.

2.4.2 Girders

Girder webs shall be modelled by means of membrane or shell elements. However, flanges may be modelled using beam and truss elements. Web and flange properties shall be according to the actual geometry. The axial stiffness of the girder is important for the global model and hence reduced efficiency of girder flanges should not be taken into account. Web stiffeners in direction of the girder should be included such that axial, shear and bending stiffness of the girder are according to the girder dimensions.

2.4.3 Pillars

Pillars should be represented by beam elements having axial and bending stiffness. Pillars may be defined as 3 node beam elements, or 2 node beam elements when 4/3 node plate elements are used.

2.4.4 Stiffeners

Stiffeners are lumped to the nearest mesh-line defined as 3/2 node beam or truss elements.

The stiffeners are to be assembled to trusses or beams by summarising relevant cross-section data and have to be arranged at the edges of the plane stress or shell elements. The cross-section area of the lumped elements is to be the same as the sum of the areas of the lumped stiffeners, bending properties are irrelevant. [Figure 5](#) shows an example of a part of a deck structure with an adjacent longitudinal wall with longitudinal stiffeners. In this case the stiffeners at the longitudinal wall and stiffeners at the deck have to be idealized by two truss elements at the intersection of the longitudinal wall and the deck. Each of the truss elements has to be assigned to different element groups: One truss to the group of the elements representing the deck structure, the other truss to the element group representing the longitudinal wall. In the example of [Figure 5](#) at the intersection of the deck and wall the deck stiffeners are assembled to one truss representing $3 \times 1.5 \cdot \text{FB } 100 \times 8$, and the wall stiffeners to an additional truss representing $1.5 \cdot \text{FB } 200 \times 10$.

The surface elements shall generally be positioned in the mid-plane of the corresponding components. For thin-walled structures, the elements can also be arranged at moulded lines, as an approximation.

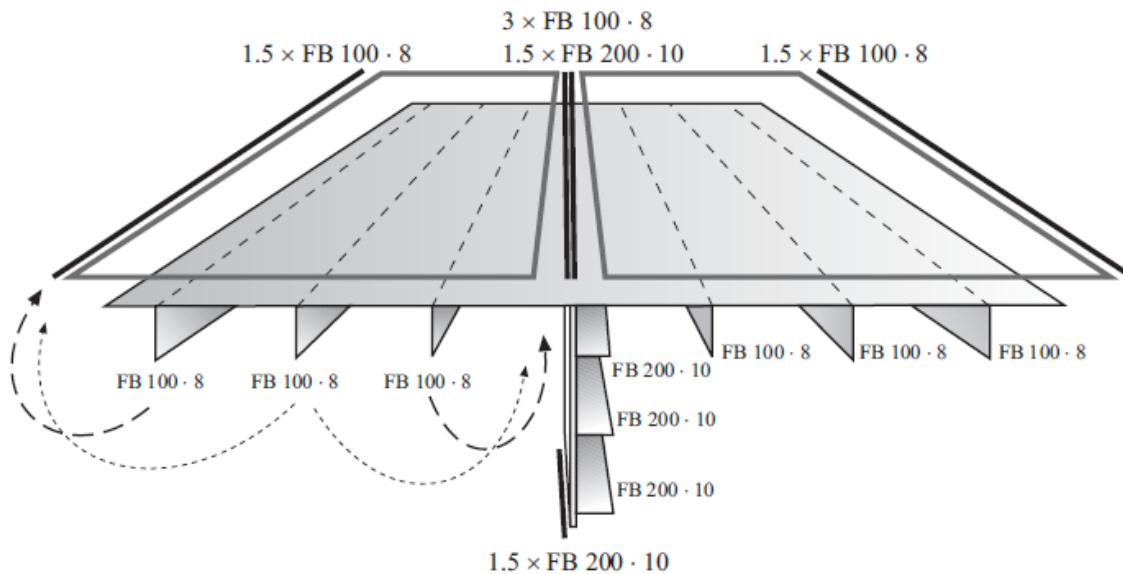

Figure 5 Example of plate and stiffener assemblies

For lumped stiffeners the eccentricity between stiffeners and plate may be disregarded. Buckling stiffeners of less importance for the stress distribution may be disregarded.

2.4.5 Openings

All window openings, door openings, deck openings and shell openings of significant size are to be represented. The openings are to be modelled such that the deformation pattern under hull shear and bending loads is adequately represented.

The reduction in stiffness can be considered by a corresponding reduction in the element thickness. Larger openings which correspond to the element size such as pilot doors, are to be considered by deleting the appropriate elements.

The reduction of plate thickness in way of cut-outs:

- a) Web plates with several adjacent cut-outs, e.g. floor and side frame plates including hopper/bilge area, longitudinal bottom girder:

$$t_{\text{red}}(y) = \frac{H-h}{H} t_0$$

$$t_{\text{red}}(x) = \frac{L-l}{L} t_0$$

$$t_{\text{red}} = \min(t_{\text{red}}(x), t_{\text{red}}(y))$$

For t_0 , L , l , H , h see [Figure 6](#).

- b) Larger areas with cut outs, e.g. wash bulkheads, and walls with doors and windows:

$$t_{red} = \frac{1}{1 + 0.0025p^2} t_0$$

p = cut-out area in %

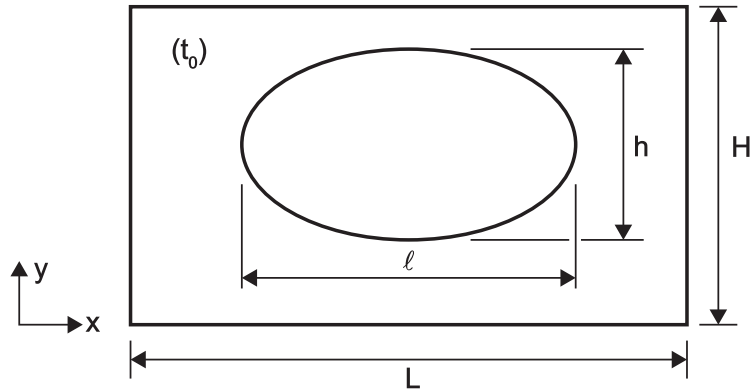

Figure 6 Cut-out

2.4.6 Simplifications

If the impact of the results is insignificant impaired, small secondary components or details that only marginally affect the stiffness can be neglected in the modelling. Examples are brackets at frames, sniped short buckling stiffeners and small cut-outs.

Steps in plate thickness or scantlings of profiles, insofar these are not situated on element boundaries, shall be taken into account by adapting element data or characteristics to obtain an equivalent stiffness.

Typical meshes used for global strength analysis are shown in [Figure 7](#) to [Figure 2-10](#).

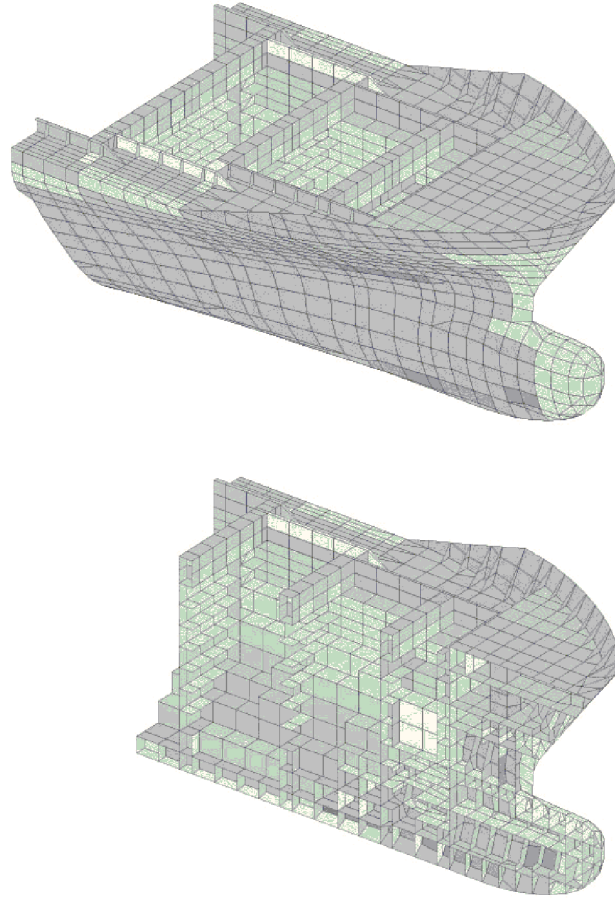

Figure 7 Typical foreship mesh used for global finite element analysis of a container ship

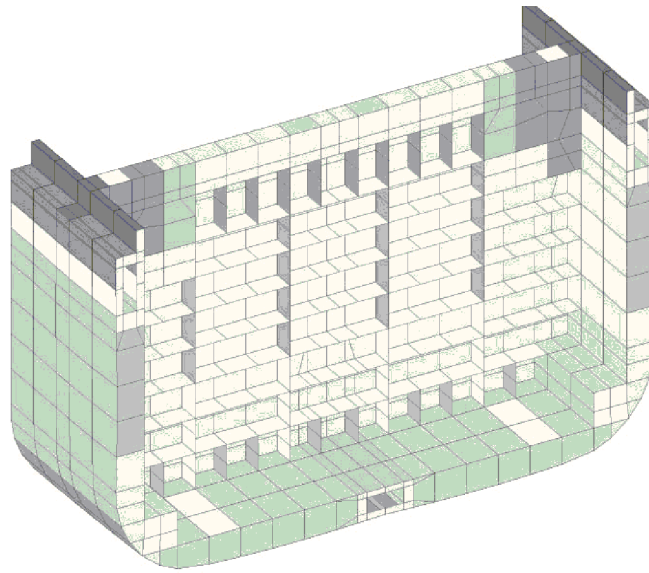

Figure 8 Typical midship mesh used for global finite element analysis of a container ship

2.5 Boundary conditions

2.5.1 General

The boundary conditions for the global structural model should reflect simple supports that will avoid built-in stresses. The boundary conditions should be specified only to prevent rigid body motions. The reaction forces in the boundaries should be minimized. The fixation points should be located away from areas of interest, as the applied loads may lead to imbalance in the model. Fixation points are often applied at the centreline close to the aft and the forward ends of the vessel.

A three-two-one fixation, as shown in [Figure 9](#), can be applied in general. For each load case, the sum of forces and reaction forces of boundary elements shall be checked.

2.5.2 Boundary conditions - Example 1

In the example 1 as shown on [Figure 9](#), fixation points are applied in the centreline close to AP and FP. The global model is supported in three positions, one in point A (in the waterline and centreline at a transverse bulkhead in the aft ship; fixed for translation along all three axes), one in point B (at the uppermost continuous deck; fixed in transverse direction) and one in point C (in the waterline and centreline at the collision bulkhead in the fore ship; fixed in vertical and transverse direction).

	Location	Direction of support	
Aft End	WL, CL (point A)	X, Y, Z	
	CL, Upper deck (point B)	Y	
Forward End	WL, CL (point C)	Y, Z	

Figure 9 Example 1 of boundary conditions

2.5.3 Boundary conditions - Example 2

The global finite element is supported in three points at engine room front bulkhead and at one point at collision bulkhead, as shown on [Figure 10](#).

	Location	Direction of support	
Engine room Front Bulkhead	SB	Z	
	CL	Y	
	PS	Z	
Collision Bulkhead	CL	X	
	CL	Y	
	CL	Z	

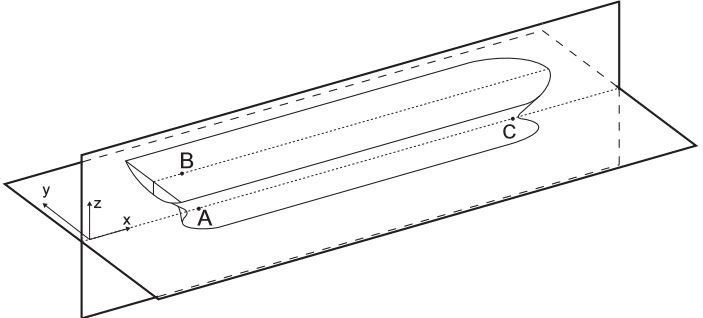
Figure 10 Example 2 of boundary conditions

2.5.4 Boundary conditions - Example 3

In the example 3, as shown on [Figure 11](#), fixation points are applied at transom intersecting main deck (port and starboard) and in the centreline close to where the stern is "rectangular". These boundary conditions may be suitable for car carrier or Ro-Ro ships.

	Location	Direction of support	
Transom	SB	Y, Z	
	PS	Z	
Forward End	CL	X, Y, Z	

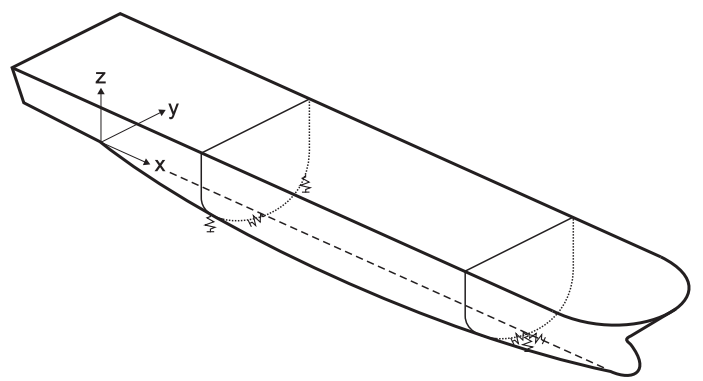
Figure 11 Example 3 of boundary conditions

3 Load application for global FE analysis

3.1 General

The design load combinations given in the rules, [RU SHIP Pt.5](#) for relevant ship type are to be applied. Results of direct wave load analysis is to be applied according to [DNVGL-CG-0130 Wave load analysis](#).

4 Analysis Criteria

4.1 General

Requirements for evaluation of results are given in the rules, [RU SHIP Pt.5](#) for relevant ship type.

For global FE model with a coarse mesh, the analysis criteria are to be applied as described in [2]. Where the global FE model is partially refined (or entirely) to mesh arrangement as used for partial ship analysis, the analysis criteria for partial ship analysis are to be applied, as given in the rules, [RU SHIP Pt.3 Ch.7 Sec.3](#). Where structural details are refined to mesh size 50 x 50 mm, the analysis criteria for local fine mesh analysis apply, as given in the rules, [RU SHIP Pt.3 Ch.7 Sec.4](#).

4.2 Yield strength assessment

4.2.1 General

Yield strength assessment is to be carried out for structural members defined in the rules, [RU SHIP Pt.5](#) for relevant ship type with acceptance criteria given in the rules, [RU SHIP Pt.3 Ch.7 Sec.3](#).

The yield acceptance criteria refer to nominal axial (normal), nominal shear and von Mises stresses derived from a global analysis.

Normally, the nominal stresses in global FE model can be extracted directly at the shell element centroid of the mid-plane (layer). In areas with high peaked stress, the nominal stress acceptance criteria are not applicable.

4.2.2 Von Mises stress

The von Mises stress, σ_{vm} , in N/mm^2 , is to be calculated based on the membrane normal and shear stresses of the shell element. The stresses are to be evaluated at the element centroid of the mid-plane (layer), as follows:

4.3 Buckling strength assessment

Buckling strength assessment is to be carried out for structural members defined in the rules, [RU SHIP Pt.5](#) for relevant ship type with acceptance criteria given in the rules, [RU SHIP Pt.3 Ch.8 Sec.4](#).

4.4 Fatigue strength assessment

Fatigue strength assessment is to be carried out for structural members defined in the rules, [RU SHIP Pt.5](#) for relevant ship type with acceptance criteria given in the rules, [RU SHIP Pt.3 Ch.9](#).

SECTION 3 PARTIAL SHIP STRUCTURAL ANALYSIS

Symbols

For symbols not defined in this section, refer to [RU SHIP Pt.3 Ch.1 Sec.4](#).

M_{sw}	= Permissible vertical still water bending moment, in kNm, as defined in the rules, RU SHIP Pt.3 Ch.4 Sec.4 .
M_{wv}	= Vertical wave bending moment, in kNm, in hogging or sagging condition, as defined in RU SHIP Pt.3 Ch.4 Sec.4 .
M_{wh}	= Horizontal wave bending moment, in kNm, as defined in the rules, RU SHIP Pt.3 Ch.4 Sec.4 .
M_{wt}	= Wave torsional moment in seagoing condition, in kNm, as defined in the rules, RU SHIP Pt.3 Ch.4 Sec.4 .
Q_{sw}	= Permissible still water shear force, in kN, at the considered bulkhead position, as provided in the rules, RU SHIP Pt.3 Ch.4 Sec.4 .
Q_{wv}	= Vertical wave shear force, in kN, as defined in the rules, RU SHIP Pt.3 Ch.4 Sec.4 .
x_{b_aft} , x_{b_fwd}	= x-coordinate, in m, of respectively the aft and forward bulkhead of the mid-hold.
x_{aft}	= x-coordinate, in m, of the aft end support of the FE model.
x_{fore}	= x-coordinate, in m, of the fore end support of the FE model.
x_i	= x-coordinate, in m, of web frame station i.
Q_{aft}	= vertical shear force, in kN, at the aft bulkhead of mid-hold as defined in [6.3.6] .
Q_{fwd}	= vertical shear force, in kN, at the fore bulkhead of mid-hold as defined in [6.3.6] .
$Q_{targ-aft}$	= target shear force, in kN, at the aft bulkhead of mid-hold as defined in [6.2.2] .
$Q_{targ-fwd}$	= target shear force, in kN, at the forward bulkhead of mid-hold as defined in [6.2.2] .

1 Objective and scope

1.1 General

This section provides procedures for partial ship finite element structural analysis as required by the rules, [RU SHIP Pt.3 Ch.7 Sec.3](#). Class Guidelines for specific ship types may provide additional guidelines.

The partial ship structural analysis is used for the strength assessment of scantlings of hull girder structural members, primary supporting members and bulkheads.

The partial ship FE model may also be used together with:

- local fine mesh analysis of structural details, see [Sec.4](#)
- fatigue assessment of structural details as required in the rules, [RU SHIP Pt.3 Ch.9](#).

For strength assessment the analysis is to verify the following:

- Stress levels are within the acceptance criteria for yielding, as given in [\[7.2\]](#).
- Buckling capability of plates and stiffened panels are within the acceptance criteria for buckling defined in [\[7.3\]](#).

1.2 Application

For cargo hold analysis, the analysis procedures including the model extent, boundary conditions, and hull girder load applications are given in this section. Class Guidelines for specific ship types may provide additional procedures. For ships without cargo hold arrangement or for evaluation areas outside cargo area, the analysis procedures given in this chapter may be applied with a special consideration.

1.3 Definitions

Definitions related to partial ship structural analysis are given in [Table 1](#). For the purpose of FE structural assessment and load application, the cargo area is divided into cargo hold regions, which may vary depending on the ship length and cargo hold arrangement, as defined in [Table 2](#).

Table 1 Definitions related to partial ship structural analysis

<i>Terms</i>	<i>Definition</i>
Partial ship analysis	The partial ship structural analysis with finite element method is used for the strength assessment of a part of the ship.
Cargo hold analysis	For ships with a cargo hold or tank arrangement, the partial ship analysis within cargo area is defined as a cargo hold analysis.
Evaluation area	The evaluation area is an area of the partial ship model, where the verification of results against the acceptance criteria is to be carried out. For a cargo hold structural analysis evaluation area is defined in [7.1.1] .
Mid-hold	For the purpose of the cargo hold analysis, the mid-hold is defined as the middle hold of a three cargo hold length FE model. In case of foremost and aftmost cargo hold assessment, the mid-hold in the model represents the foremost or aftmost cargo hold including the slop tank if any, respectively.
FE load combination	A FE load combination is defined as a loading pattern, a draught, a value of still water bending and shear force, associated with a given dynamic load case to be used in the finite element analysis.

Table 2 Definition of cargo hold regions for FE structural assessment

<i>Cargo hold region</i>	<i>Definition</i>
Forward cargo hold region	Holds with their longitudinal centre of gravity position forward of $0.7 L$ from AE, except foremost cargo hold
Midship cargo hold region	Holds with their longitudinal centre of gravity position at or forward of $0.3 L$ from AE and at or aft of $0.7 L$ from AE.
After cargo hold region	Holds with their longitudinal centre of gravity position aft of $0.3 L$ from AE, except aftmost cargo hold.
Foremost cargo hold(s)	Hold(s) in the foremost location of the cargo hold region.
Aftmost cargo hold(s)	Hold(s) in the aftmost location of the cargo hold region.

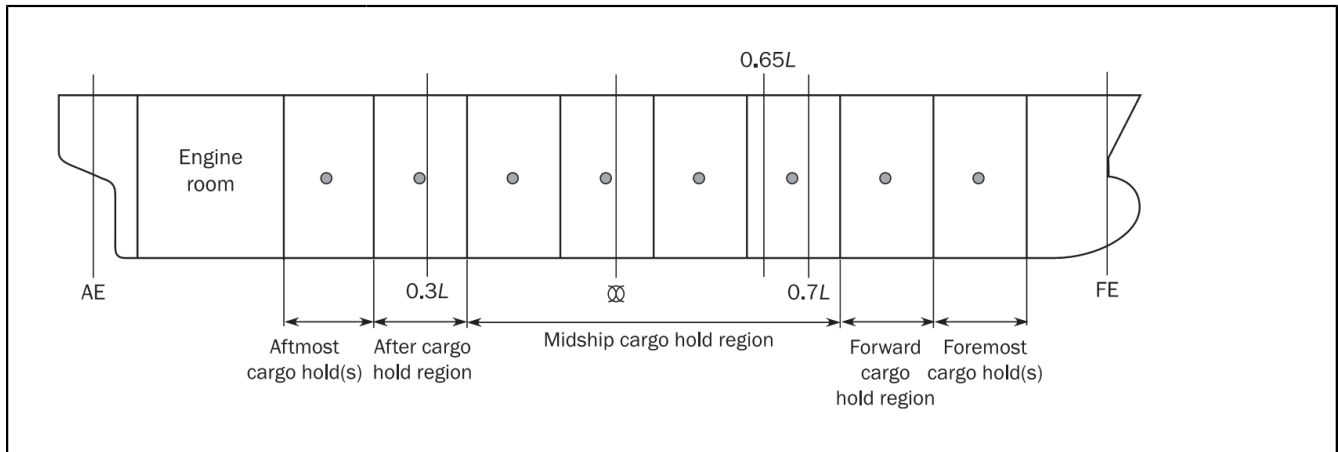

1.4 Procedure of cargo hold analysis

1.4.1 Procedure description

Cargo hold FE analysis is to be performed in accordance with the following:

- Model: Three cargo hold model with:
 - Extent as given in [2.1]
 - Structural modelling as defined in [2.2].
- Boundary conditions as defined in [3]
- FE load combinations as defined in [4]
- Load application as defined in [4.5]
- Evaluation area as defined in [7.1]
- Strength assessment as defined in [7.2] and [7.3].

1.5 Scantlings assessment

1.5.1 The analysis procedure enables to carry out the cargo hold analysis of individual cargo hold(s) within cargo area. One midship cargo hold analysis of the ship with a regular cargo holds arrangement will normally be considered applicable for the entire midship cargo hold region.

1.5.2 Where the holds in the midship cargo hold region are of different lengths, the mid-hold of the FE model will normally represent the cargo hold of the greatest length. In addition, the selection of the hold for the analysis is to be carefully considered with respect to loads. The analyzed hold shall represent the most critical responses due to applied loads. Otherwise, separate analyses of individual holds may be required in the midship cargo hold region.

1.5.3 FE analysis outside midship region may be required if the structure or loads are substantially different from that of the midship region. Otherwise, the scantlings assessment shall be based on beam analysis. The FE analysis in the midship region may need to be modified considering changes in the structural arrangement and loads.

2 Structural model

2.1 Extent of model

2.1.1 General

The FE model extent for cargo hold analysis is defined in [2.1.2]. For partial ship analysis other than cargo hold analysis, the model extent depends on the evaluation area and the structural arrangement and needs to be considered on a case by case basis. In general, the FE model for partial ship analysis is to extend so that the model boundaries at the models end are adequately remote from the evaluation area.

2.1.2 Extent of model in cargo hold analysis

Longitudinal extent

Normally, the longitudinal extent of the cargo hold FE model is to cover three cargo hold lengths. The transverse bulkheads at the ends of the model can be omitted. Typical finite element models representing the midship cargo hold region of different ship type configurations are shown in Figure 2 and Figure 3.

The foremost and the aftmost cargo holds are located at the middle of FE models, as shown in Figure 1.

Examples of finite element models representing the aftermost and foremost cargo hold are shown in Figure 4 and Figure 5.

Transverse extent

Both port and starboard sides of the ship are to be modelled.

Vertical extent

The full depth of the ship is to be modelled including primary supporting members above the upper deck, trunks, forecastle and/or cargo hatch coaming, if any. The superstructure or deck house in way of the machinery space and the bulwark are not required to be included in the model.

2.1.3 Hull form modelling

In general, the finite element model is to represent the geometry of the hull form. In the midship cargo hold region, the finite element model may be prismatic provided the mid-hold has a prismatic shape.

In the foremost cargo hold model, the hull form forward of the transverse section at the middle of the fore part up to the model end may be modelled with a simplified geometry. The transverse section at the middle of the fore part up to the model end may be extruded out to the fore model end, as shown in Figure 1.

In the aftmost cargo hold model, the hull form aft of the middle of the machinery space may be modelled with a simplified geometry. The section at the middle of the machinery space may be extruded out to its aft bulkhead, as shown in Figure 1.

When the hull form is modelled by extrusion, the geometrical properties of the transverse section located at the middle of the considered space (fore or machinery space) can be copied along the simplified model. The transverse web frames can be considered along this extruded part with the same properties as the ones in the mid part or in the machinery space.

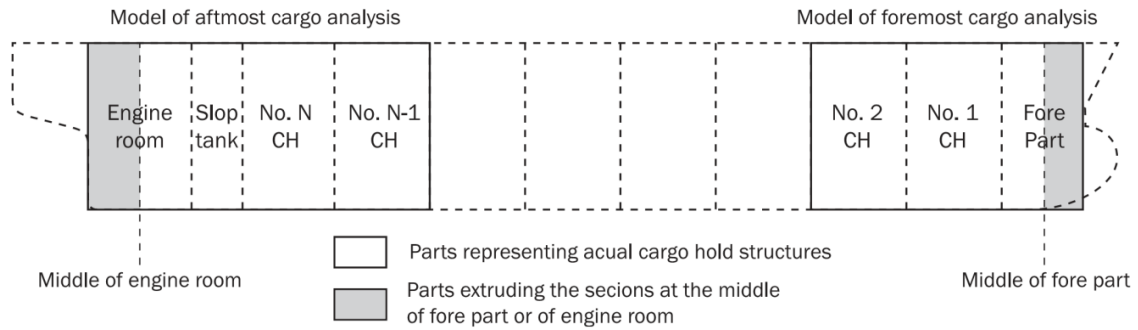

Figure 1 Hull form simplification for foremost and aftmost cargo hold model

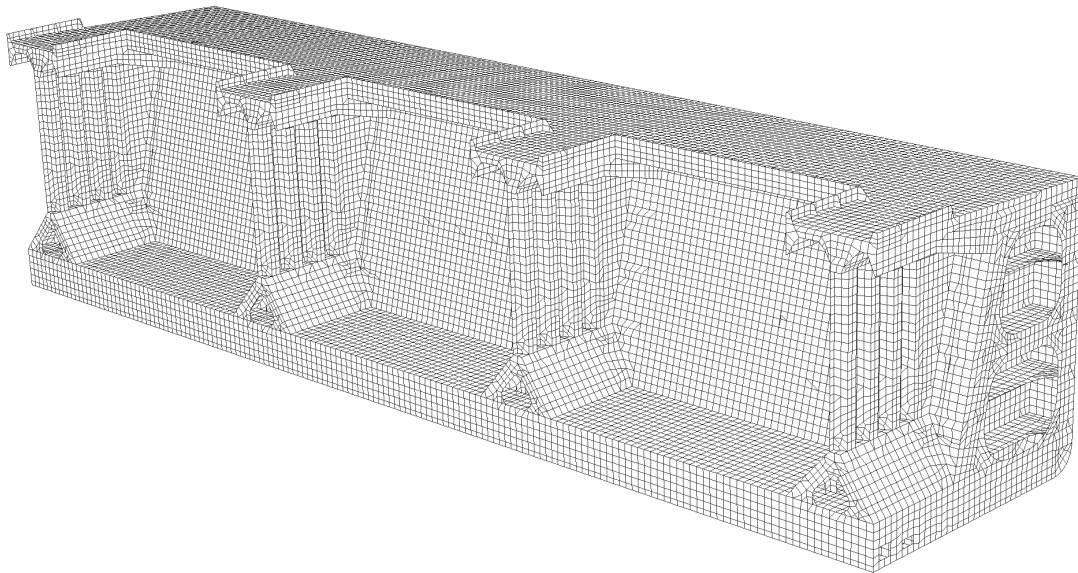

Figure 2 Example of 3 cargo hold model within midship region of an ore carrier (shows only port side of the full breadth model)

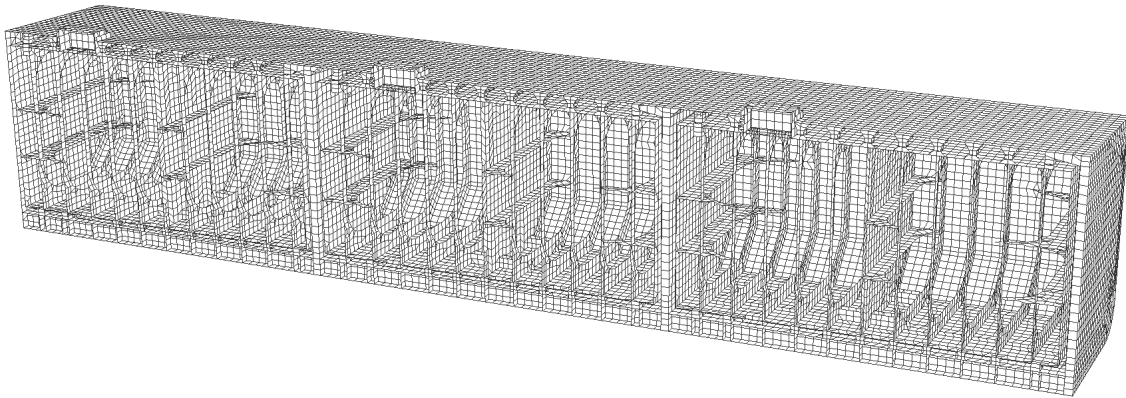

Figure 3 Example of 3 cargo hold model within midship region of a LPG carrier (independent tank design) (shows only port side of the full breadth model)

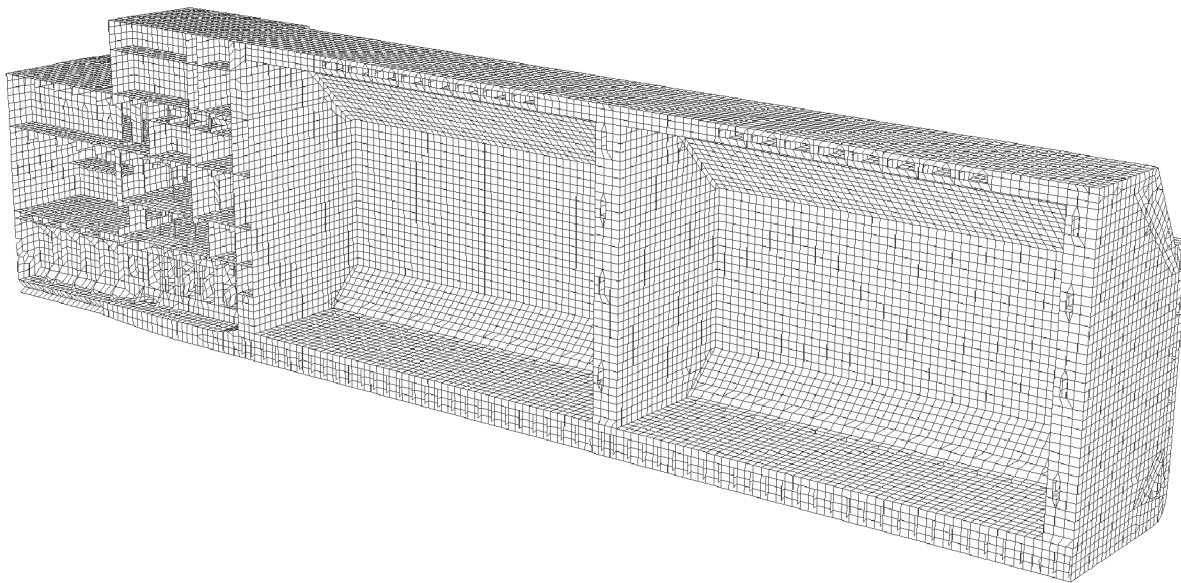

Figure 4 Example of FE model for the aftermost cargo hold structure of a LNG carrier (membrane tank design) (shows only port side of the full breadth model)

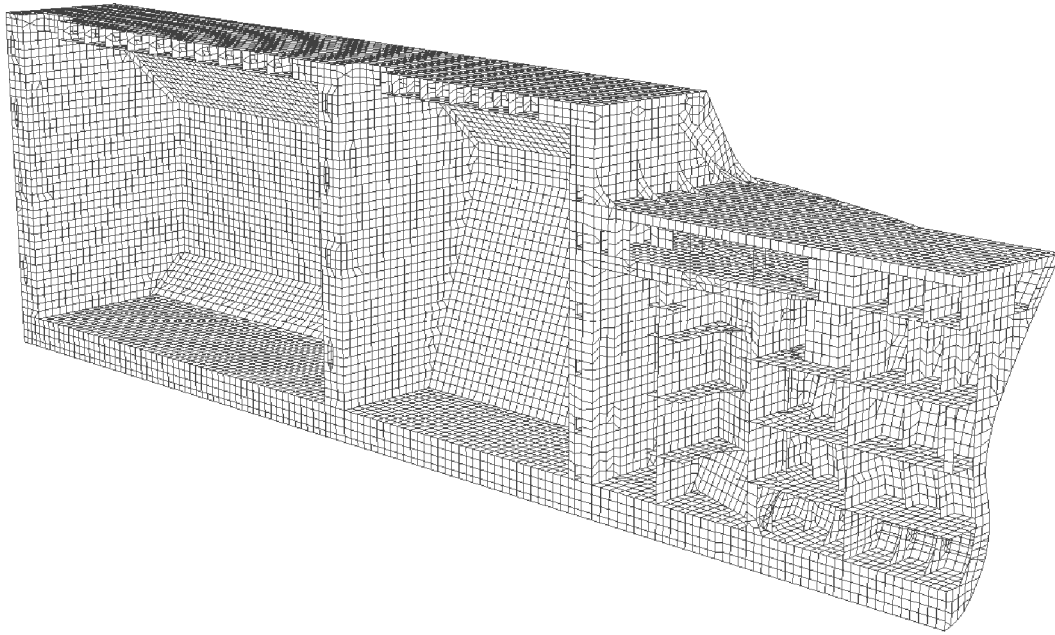

Figure 5 Example of FE model for the foremost cargo hold structure of a LNG carrier (membrane tank design) (shows only port side of the full breadth model)

2.2 Structural modelling

2.2.1 General

The aim of the cargo hold FE analysis is to assess the overall strength of the structure in the evaluation areas. Modelling the ship's plating and stiffener systems with a with stiffener spacing mesh size, $s \times s$, as described below is sufficient to carry out yield assessment and buckling assessment of the main hull structures.

2.2.2 Structures to be modelled

Within the model extents, all main longitudinal and transverse structural elements should be modelled. All plates and stiffeners on the structure, including web stiffeners, are to be modelled. Brackets which contribute to primary supporting member strength, where the size is larger than the typical mesh size ($s \times s$) are to be modelled.

2.2.3 Finite elements

Shell elements are to be used to represent plates. All stiffeners are to be modelled with beam elements having axial, torsional, bi-directional shear and bending stiffness. The eccentricity of the neutral axis is to be modelled. Alternatively, concentric beams (in NA of the beam) can be used providing that the out of plane bending properties represent the inertia of the combined plating and stiffener. The width of the attached plate is to be taken as $\frac{1}{2} + \frac{1}{2}$ stiffener spacing on each side of the stiffener.

2.2.4 Mesh

The shell element mesh is to follow the stiffening system as far as practicable, hence representing the actual plate panels between stiffeners, i.e. $s \times s$, where s is stiffeners spacing. In general, the shell element mesh is to satisfy the following requirements:

- a) One element between every longitudinal stiffener, see [Figure 6](#). Longitudinally, the element length is not to be greater than 2 longitudinal spaces with a minimum of three elements between primary supporting members.
- b) One element between every stiffener on transverse bulkheads, see [Figure 7](#).
- c) One element between every web stiffener on transverse and vertical web frames, cross ties and stringers, see [Figure 6](#) and [Figure 8](#).
- d) At least 3 elements over the depth of double bottom girders, floors, transverse web frames, vertical web frames and horizontal stringers on transverse bulkheads. For cross ties, deck transverse and horizontal stringers on transverse wash bulkheads and longitudinal bulkheads with a smaller web depth, modelling using 2 elements over the depth is acceptable provided that there is at least 1 element between every web stiffener. For a single side ship, 1 element over the depth of side frames is acceptable. The mesh size of adjacent structure is to be adjusted accordingly.
- e) The mesh on the hopper tank web frame and the topside web frame is to be fine enough to represent the shape of the web ring opening, as shown in [Figure 6](#).
- f) The curvature of the free edge on large brackets of primary supporting members is to be modelled to avoid unrealistic high stress due to geometry discontinuities. In general, a mesh size equal to the stiffener spacing is acceptable. The bracket toe may be terminated at the nearest nodal point provided that the modelled length of the bracket arm does not exceed the actual bracket arm length. The bracket flange is not to be connected to the plating, as shown in [Figure 9](#). The modelling of the tapering part of the flange is to be in accordance with [\[2.2.7\]](#). An example of acceptable mesh is shown in [Figure 9](#).

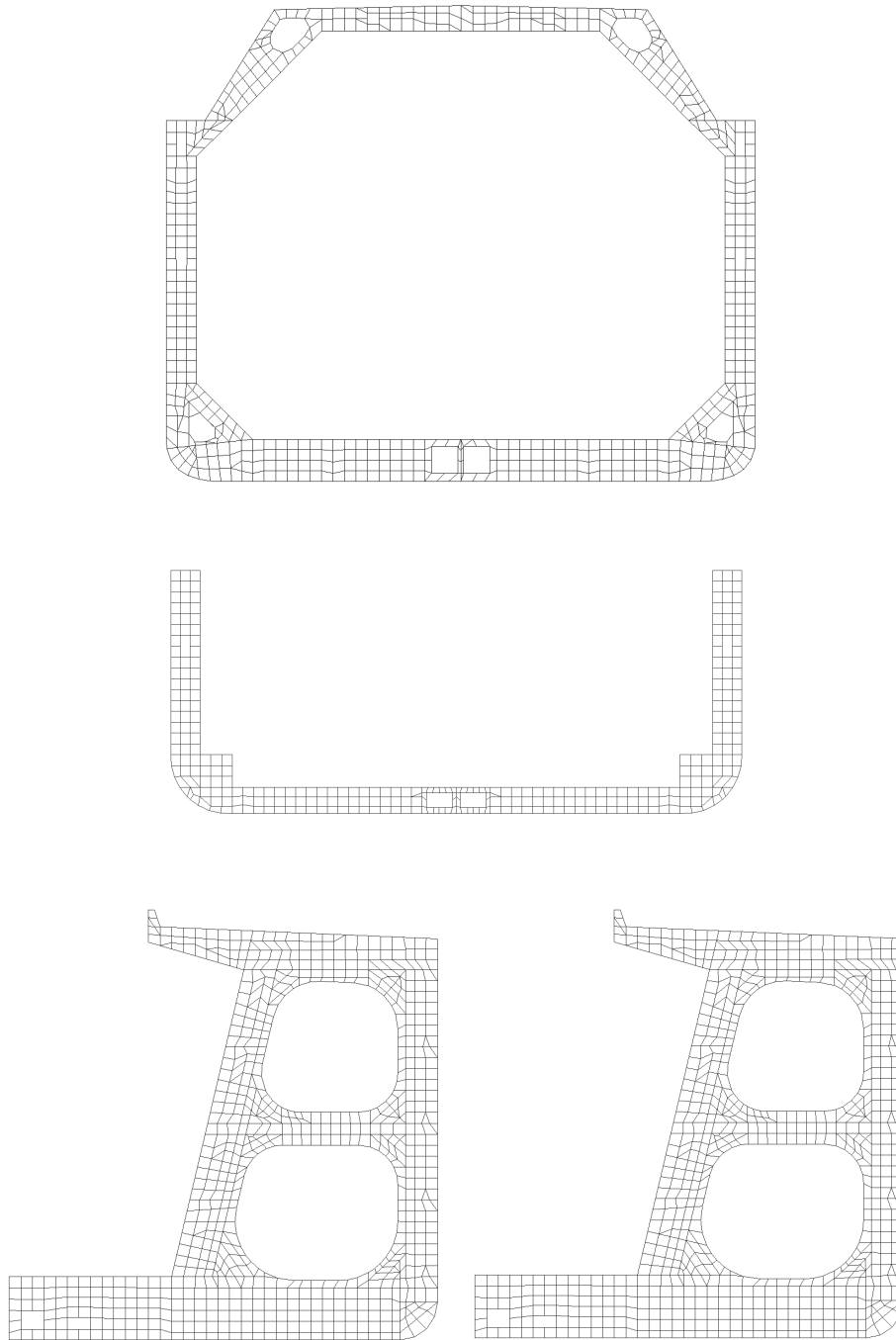

Figure 6 Typical finite element mesh on web frame of different ship types

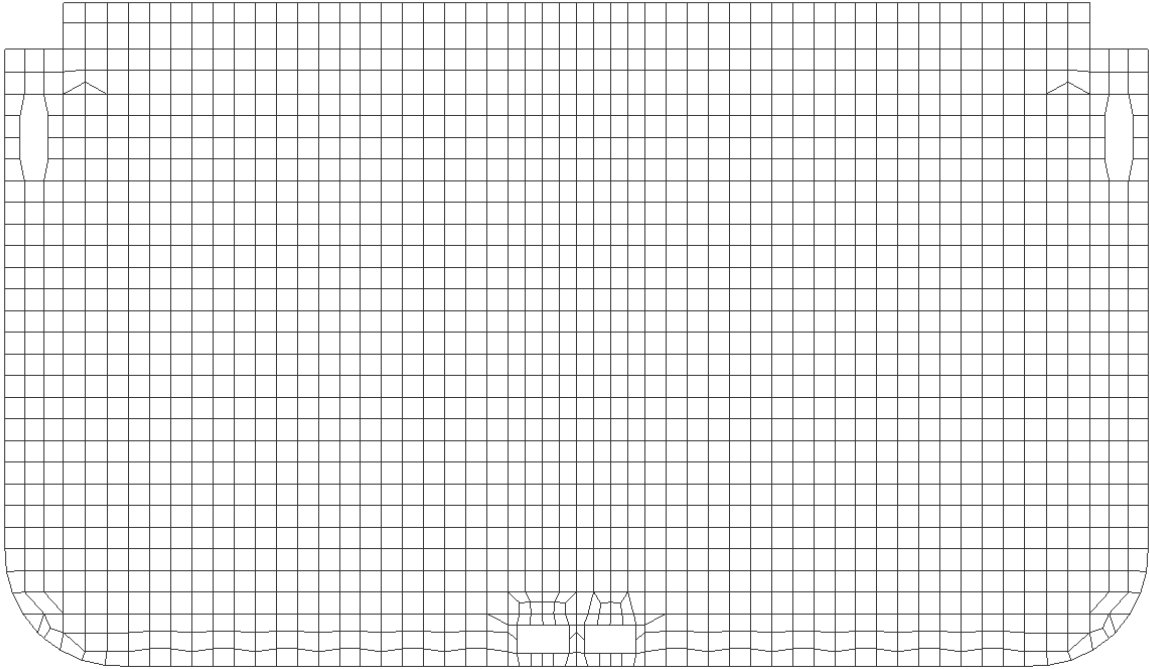
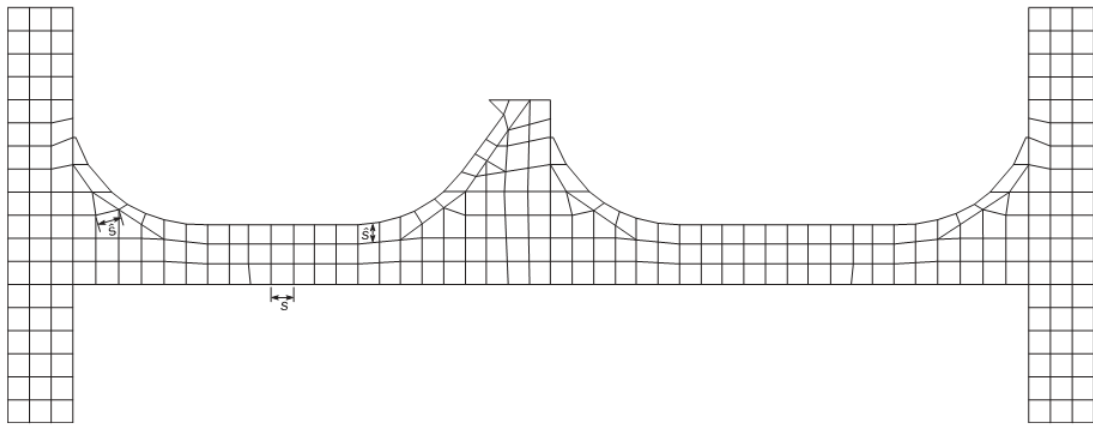

Figure 7 Typical finite element mesh on transverse bulkhead



s = Stiffener spacing

Figure 8 Typical finite element mesh on horizontal transverse stringer on transverse bulkhead

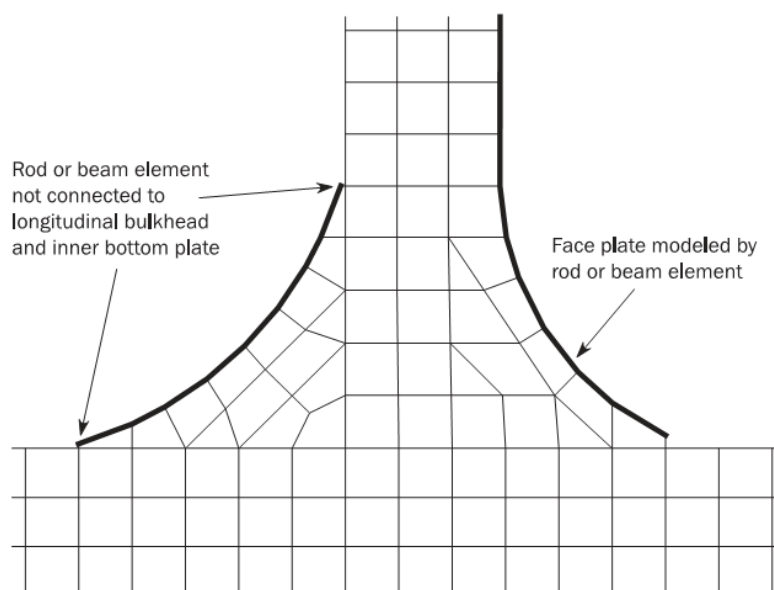

Figure 9 Typical finite element mesh on transverse web frame main bracket

2.2.5 Corrugated bulkhead

Diaphragms in the stools, supporting structure of corrugated bulkheads and internal longitudinal and vertical stiffeners on the stool plating are to be included in the model. Modelling is to be carried out as follows:

- a) The corrugation is to be modelled with its geometric shape.
- b) The mesh on the flange and web of the corrugation is in general to follow the stiffener spacing inside the bulkhead stool.
- c) The mesh on the longitudinal corrugated bulkhead shall follow longitudinal positions of transverse web frames, where the corrections to hull girder vertical shear forces are applied in accordance with [6.3.5].
- d) The aspect ratio of the mesh in the corrugation is not to exceed 2 with a minimum of 2 elements for the flange breadth and the web height.
- e) Where difficulty occurs in matching the mesh on the corrugations directly with the mesh on the stool, it is acceptable to adjust the mesh on the stool in way of the corrugations.
- f) For a corrugated bulkhead without an upper stool and/or lower stool, it may be necessary to adjust the geometry in the model. The adjustment is to be made such that the shape and position of the corrugations and primary supporting members are retained. Hence, the adjustment is to be made on stiffeners and plate seams if necessary.
- g) Dummy rod elements with a cross sectional area of 1 mm^2 are to be modelled at the intersection between the flange and the web of corrugation, see Figure 10. It is recommended that dummy rod elements are used as minimum at the two corrugation knuckles closest to the intersection between:
 - Transverse and longitudinal bulkheads,
 - Transverse bulkhead and inner hull,
 - Transverse bulkhead and side shell.
- h) As illustrated in Figure 10, in areas of the corrugation intersections the normal stresses are not constant across the corrugation flanges. The maximum stresses due to bending of the corrugation under lateral pressure in different loading configurations occur at edges on the corrugation. The dummy rod elements capture these stresses. In other areas there is no need to include dummy elements in the model as normally the stresses are constant across the corrugation flanges and the stress results in the shell elements are sufficient.

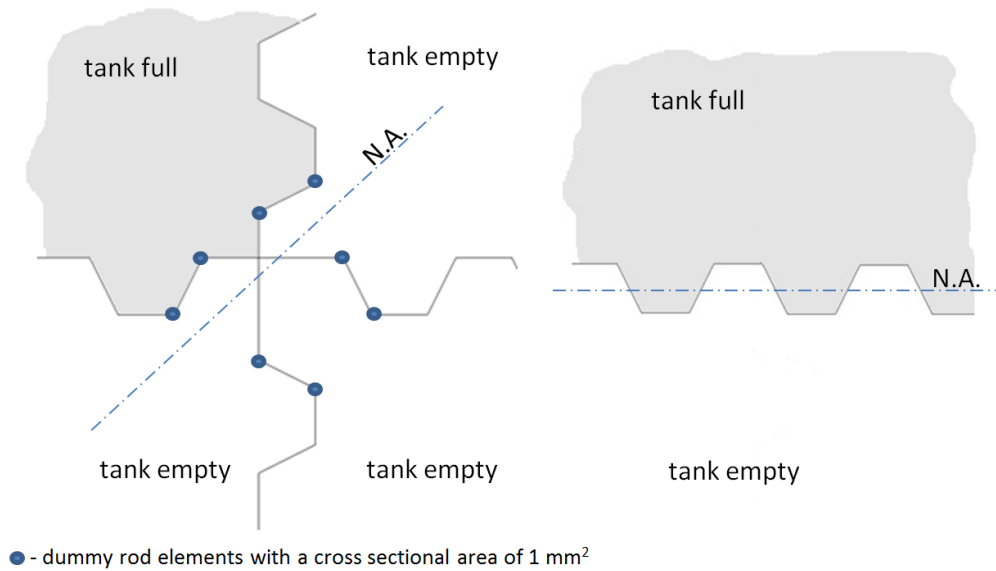

Figure 10 Example of dummy rod elements at the corrugation.

Example of mesh arrangements of the cargo hold structures are shown in [Figure 11](#) and [Figure 12](#).

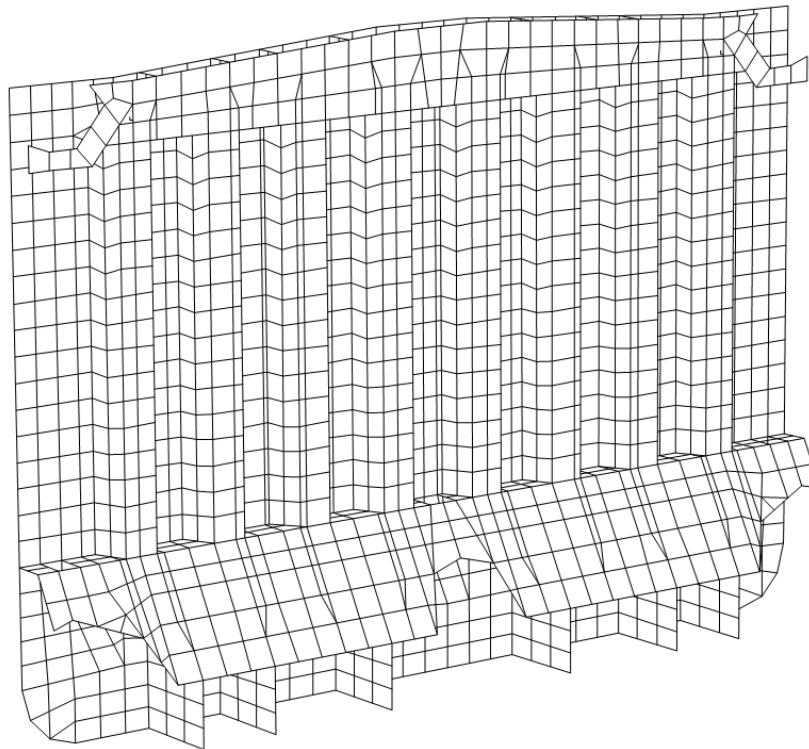

Figure 11 Example of FE mesh on transverse corrugated bulkhead structure for a product tanker

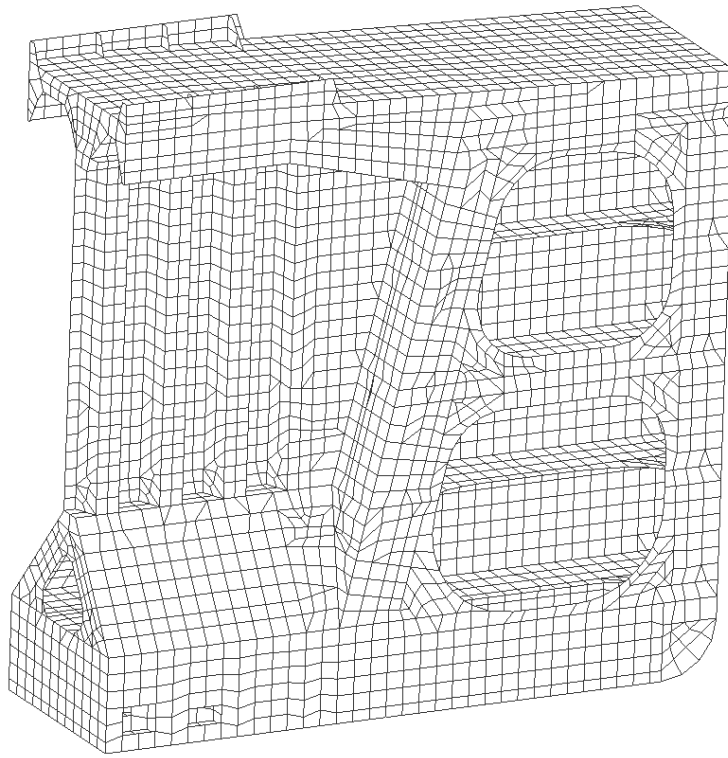

Figure 12 Example of FE mesh on transverse bulkhead structure for an ore carrier

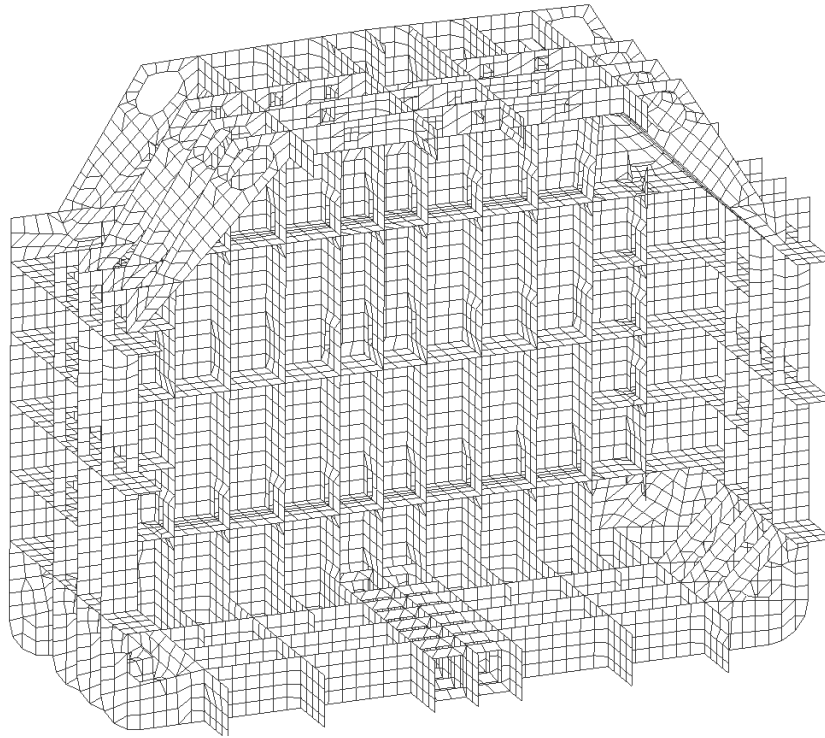

Figure 13 Example of FE mesh arrangement of cargo hold structure for a gas carrier ship

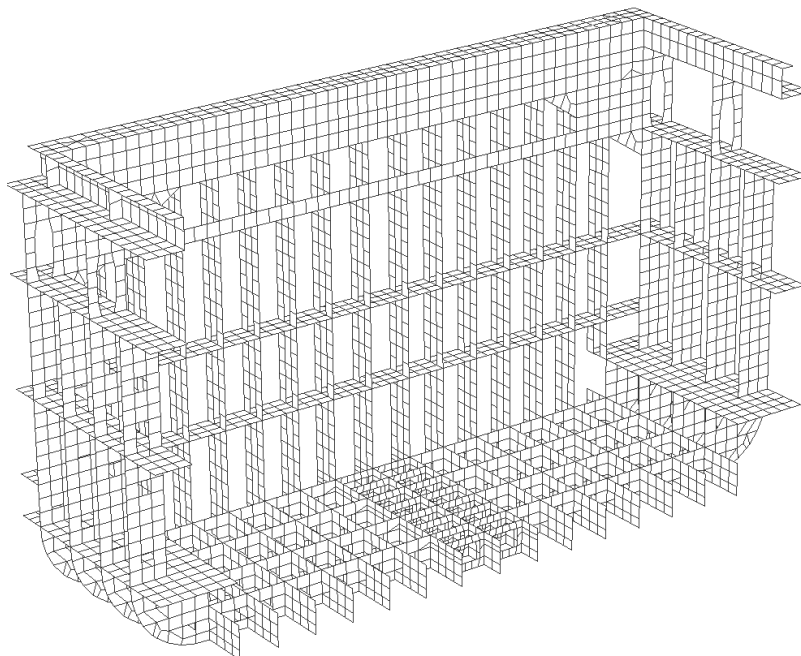

Figure 14 Example of FE mesh arrangement of cargo hold structure for a container ship

2.2.6 Stiffeners

Web stiffeners on primary supporting members are to be modelled. Where these stiffeners are not in line with the primary FE mesh, it is sufficient to place the line element along the nearby nodal points provided that the adjusted distance does not exceed 0.2 times the stiffener spacing under consideration. The stresses and buckling utilisation factors obtained need not be corrected for the adjustment. Buckling stiffeners on large brackets, deck transverses and stringers parallel to the flange are to be modelled. These stiffeners may be modelled using rod elements. Non continuous stiffeners may be modelled as continuous stiffeners, i.e. the height web reduction in way of the snip ends is not necessary.

2.2.7 Face plate of primary supporting member

Face plates of primary supporting members and brackets are to be modelled using rod or beam elements. The effective cross sectional area at the curved part of the face plate of primary supporting members and brackets is to be calculated in accordance with the rules, [RU SHIP Pt.3 Ch.3 Sec.7 \[1.3.3\]](#). The cross sectional area of a rod or beam element representing the tapering part of the face plate is to be based on the average cross sectional area of the face plate in way of the element length.

2.2.8 Openings

In the following structures, manholes and openings of about element size ($s \times s$) or larger are to be modelled by removing adequate elements, e.g. in:

- primary supporting member webs such as floors, side webs, bottom girders, deck stringers and other girders and
- other non-tight structures such as wing tank webs, hopper tank webs, diaphragms in the stool of corrugated bulkhead.

For openings of about manhole size it is sufficient to delete one element, with a length and height between 70% and 150% of the actual opening. The FE-mesh is to be arranged to accommodate the opening size as far as practical. For larger openings with length and height of at least of two elements ($2s$) the contour of the opening shall be modelled as much as practical with the applied mesh size, see [Figure 15](#).

In case of sequential openings the web stiffener and the remaining web plate between the openings is to be modelled by beam element(s) and to be extend into the shell elements adjacent of the opening, see [Figure 16](#).

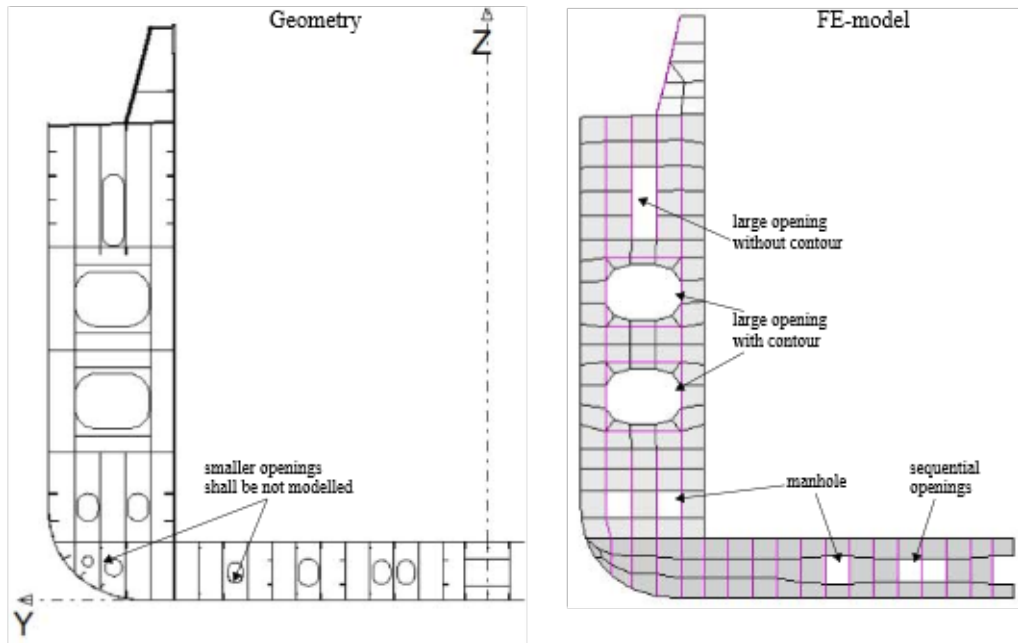

Figure 15 Modelling of openings in a transverse frame

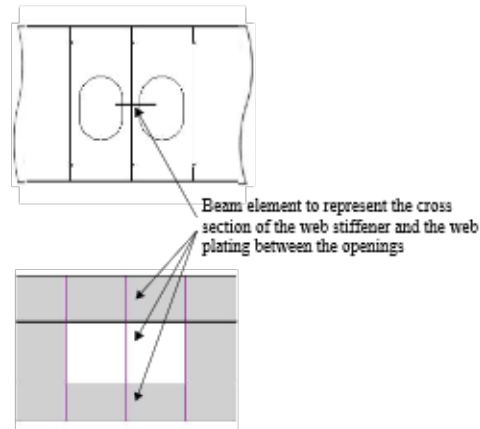

Figure 16 Modelling in way of sequential openings

3 Boundary conditions

3.1 General

The boundary conditions for the cargo hold analysis are defined in [3.2]. For partial ship analysis other than cargo holds analysis, the boundary condition need to be considered on a case by case basis. In general, the model needs to be supported at the model's end(s) to prevent rigid body motions and to absorb unbalanced

shear forces. The boundary conditions shall not introduce abnormal stresses into the evaluation area. Where relevant, the boundary condition shall enable the adjustment of hull girder loads, such as hull girder bending moments or shear forces.

3.2 Boundary conditions in cargo hold analysis

3.2.1 Model constraints

The boundary conditions consist of the rigid links at model ends, point constraints and end-beams. The rigid links connect the nodes on the longitudinal members at the model ends to an independent point at neutral axis in centreline. The boundary conditions to be applied at the ends of the cargo hold FE model, except for the foremost cargo hold, are given in [Table 3](#). For the foremost cargo hold analysis, the boundary conditions to be applied at the ends of the cargo hold FE model are given in [Table 4](#).

Rigid links in y and z are applied at both ends of the cargo hold model so that the constraints of the model can be applied to the independent points. Rigid links in x-rotation are applied at both ends of the cargo hold model so that the constraint at fore end and required torsion moment at aft end can be applied to the independent point. The x-constraint is applied to the intersection between centreline and inner bottom at fore end to ensure the structure has enough support.

Table 3 Boundary constraints at model ends except the foremost cargo hold models

Location	Translation			Rotation		
	δ_x	δ_y	δ_z	θ_x	θ_y	θ_z
Aft End						
Independent point	-	Fix	Fix	$M_{T-end}^{(4)}$	-	-
Cross section	-	Rigid link	Rigid link	Rigid link	-	-
	End beam, see [3.2.2]					
Fore End						
Independent point	-	Fix	Fix	Fix	-	-
Intersection of centreline and inner bottom ⁽³⁾	Fix	-	-	-	-	-
Cross section	-	Rigid link	Rigid link	Rigid link	-	-
	End beam, see [3.2.2]					
Note 1: [-] means no constraint applied (free).						
Note 2: See Figure 17 .						
Note 3: Fixation point may be applied on other continuous structures such as outer bottom at centreline. If exists, the fixation point can be applied at any location of longitudinal bulkhead at centreline, except independent point location.						
Note 4: hull girder torsional moment adjustment in kNm, as defined in [6.4.4] .						

Table 4 Boundary constraints at model ends of the foremost cargo hold model

Location	Translation			Rotation		
	δ_x	δ_y	δ_z	θ_x	θ_y	θ_z
Aft End						
Independent point	-	Fix	Fix	Fix	-	-
Cross section	-	Rigid link	Rigid link	Rigid link	-	-
	End beam, see [3.2.2]					
Fore End						
Independent point	-	Fix	Fix	$M_{T-end}^{(5)}$	-	-
Intersection of centreline and inner bottom ⁽⁴⁾	Fix	-	-	-	-	-
Cross section	-	Rigid link	Rigid link	Rigid link	-	-
<p>Note 1: [-] means no constraint applied (free).</p> <p>Note 2: See Figure 17.</p> <p>Note 3: Boundary constraints in fore end shall be located at the most forward reinforced ring or web frame which remains continuous from the base line to the strength deck.</p> <p>Note 4: Fixation point may be applied on other continuous structures such as outer bottom at centreline. If exists, the fixation point can be applied at any location of longitudinal bulkhead at centreline, except independent point location.</p> <p>Note 5: hull girder torsional moment adjustment in kNm, as defined in [6.4.4].</p>						

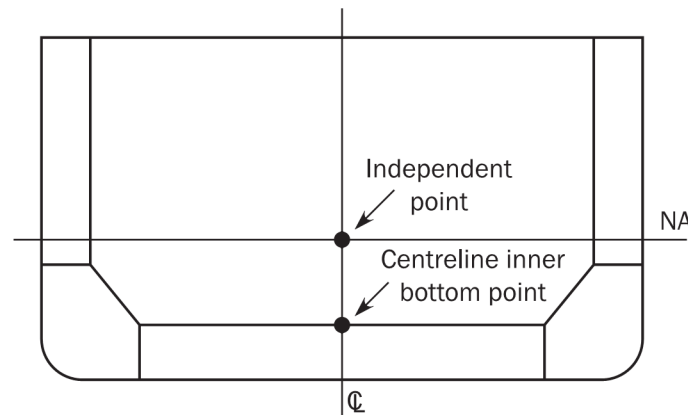
**Figure 17 Boundary conditions applied at the model end sections**

3.2.2 End constraint beams

In order to simulate the warping constraints from the cut-out structures the end beams are to be applied at both ends of the cargo hold model. Under torsional load, this out of plane stiffness acts as warping constraint. End constraint beams are to be modelled at the both end deck sections of the model along all longitudinally continuous structural members and along the cross deck plating. An example of end beams at one end for a double hull bulk carrier is shown in Figure 18.

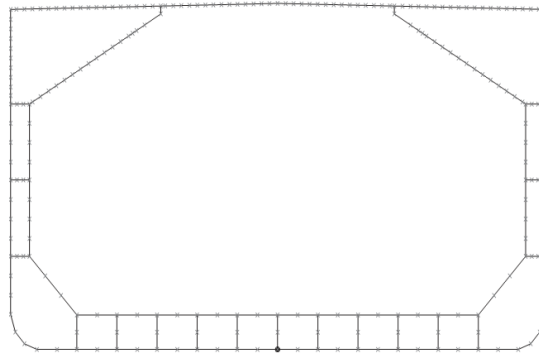

Figure 18 Example of end constraint beams for a bulk carrier

The properties of beams are calculated at fore and aft sections separately and all beams at each end section have identical properties as follows:

$$I_{Byy-n50} = I_{Bzz-n50} = I_{Bxx-n50} (J) = 0.04 I_{yy-n50}$$

$$A_{By-n50} = A_{Bz-n50} = 0.0125 A_{x-n50}$$

where:

$I_{Byy-n50}$	= moment of inertia about local beam Y axis, in m^4 .
$I_{Bzz-n50}$	= moment of inertia about local beam Z axis, in m^4 .
$I_{Bxx-n50} (J)$	= beam torsional moment of inertia, in m^4 .
A_{By-n50}	= shear area in local beam Y direction, in m^2 .
A_{Bz-n50}	= shear area in local beam Z direction, in m^2 .
I_{yy-n50}	= net vertical hull girder moment of inertia of fore/aft end cross sections of the FE model, in m^4 .
A_{x-n50}	= net cross sectional area of fore/aft end sections of the FE model, in m^2 .

4 FE load combinations and load application

4.1 Sign convention

Unless otherwise mentioned in this section, the sign of moments and shear force is to be in accordance with the sign convention defined in the rules, [RU SHIP Pt.3 Ch.4 Sec.1](#), i.e. in accordance with the right-hand rule.

4.2 Design rule loads

Design loads are to provide an envelope of the typical load scenarios anticipated in operation. The combinations of the ship static and dynamic loads which are likely to impose the most onerous load regimes on the hull structure are to be investigated in the partial ship structural analysis. Design loads used for partial ship FE analysis are to be based on the design load scenarios, as given in the rules [Pt.3 Ch.4 Sec.7 Table 1](#) and [Table 2](#) for strength and fatigue strength assessment respectively.

4.3 Rule FE load combinations

Where FE load combinations are specified in the rules, [RU SHIP Pt.5](#) for a considered ship type and cargo hold region these load combinations are to be used in the partial ship FE analysis. In case the loading

conditions specified by the designer are not covered by the FE load combinations given in the rules, [RU SHIP Pt.5](#), these additional loading conditions are to be examined according to the procedures given in this section.

4.4 Principles of FE load combinations

4.4.1 General

Each design load combination consists of a loading pattern and dynamic load cases. Each load combination requires the application of the structural weight, internal and external pressures and hull girder loads. For seagoing condition, both static and dynamic load components (S+D) are to be applied. For harbour and tank testing condition, only static load components (S) are to be applied. Other loading scenarios may be required for specific ship types, as given in the rules, [RU SHIP Pt.5](#). Design loads for partial ship analysis are represented with FE load combinations.

4.4.2 FE Load combination table

FE load combination consist the combination of the following load components:

- a) Loading pattern - configuration of the internal load arrangements within the extent of the FE model. The most severe realistic loading conditions with the ship are to be considered.
- b) Draught – the corresponding still water draught in way of considered hold/area for a given loading pattern. Draught and Loading pattern shall be combined in such way that the net loads acting on the individual structures are maximized e.g. the combination of the minimum possible draught with full hold is to be considered as well as the maximum possible draught in way of empty hold.
- c) C_{BM-LC} – Percentage of permissible still water bending moment, M_{SW} . This defines a portion of the M_{SW} to be applied to the model for a considered Loading pattern and Draught. Normally in cargo area, hull girder vertical bending moment applies to all considered loading combinations either in sagging or hogging condition (see also [\[6.2.1\]](#), [\[6.3\]](#)).
- d) C_{SF-LC} - Percentage of permissible still water shear force still water Q_{SW} . This defines a portion of the Q_{SW} to be applied to the model for a considered Loading pattern and Draught. Normally, hull girder shear forces are to be considered with alternate Loading patterns where hull girder shear stresses are governing in a total stress in way of transverse bulkheads. Then such a load combination is defined as maximum shear force load combination (Max SFLC) and relevant adjustment method applies (see also [\[6.2.2\]](#), [\[6.3\]](#)).
- e) Dynamic load case – 1 of 22 Equivalent Design Waves (EDW) to be used for determining the dynamic loads, as given in the rules, [RU SHIP Pt.3 Ch.4 Sec.2](#). One dynamic load case consists of dynamic components of internal and external local loads and hull girder loads (vertical and horizontal wave bending moment, wave shear force, and wave torsional moment). In general all dynamic load cases are applicable for one combination of a loading pattern and still water loads in seagoing loading scenario (S +D). However, the following considerations in combining a loading pattern with selected Dynamic load cases may result with the most onerous loads on the hull structure:
 - The hull girder loads are maximised by combining a static loading pattern with dynamic load cases that have hull girder bending moments/shear forces of the same sign.
 - The net local load on primary supporting structural members is maximised by combining each static loading pattern with appropriate dynamic load cases, taking into account the local load acting on the structural member and influence of the local loads acting on an adjacent structure.

FE load combinations can be defined as shown in [Table 5](#).

Table 5 FE load combination table

No.	Loading pattern	Still water loads			Dynamic load cases
		Draught	C_{BM-LC} : % of perm. SWBM	C_{SF-LC} : % of perm. SWSF	
Seagoing conditions (S+D)					
1	(a)	(b)	(c)	(d)	(e)
2					
Harbour condition (S)					
...	(a)	(b)	(c)	(d)	N/A
...					N/A
(a), (b), (c), (d), (e) as defined above					

4.5 Load application

4.5.1 Structural weight

Effect of the weight of hull structure is to be included in static loads, but is not to be included in dynamic loads. Density of steel is to be taken as given in [Sec.1 \[1.4\]](#).

4.5.2 Internal and external loads

Internal and external loads are to be applied to the FE partial ship model as given in [\[5\]](#).

4.5.3 Hull girder loads

Hull girder loads are to be applied to the FE partial ship model as given in [\[6\]](#).

5 Internal and external loads

5.1 Pressure application on FE element

Constant pressure, calculated at the element's centroid, is applied to the shell element of the loaded surfaces, e.g. outer shell and deck for the external pressure and tank/hold boundaries for the internal pressure. Alternately, pressure can be calculated at element nodes applying linear pressure distribution within elements.

5.2 External pressure

External pressure is to be calculated for each load case in accordance with the rules, [RU SHIP Pt.3 Ch.4 Sec.5](#). External pressures include static sea pressure, wave pressure and green sea pressure.

The forces applied on the hatch cover by the green sea pressure are to be distributed along the top of the corresponding hatch coamings. The total force acting on the hatch cover is determined by integrating the hatch cover green sea pressure as defined in the rules, [RU SHIP Pt.3 Ch.4 Sec.5 \[2.2\]](#). Then the total force is to be distributed to the total length of the hatch coamings using the average line load. The effect of the hatch cover self-weight is to be ignored in the loads applied to the ship structure.

5.3 Internal pressure

Internal pressure is to be calculated for each load case in accordance with the rules, [RU SHIP Pt.3 Ch.4 Sec.6](#) for design load scenarios given in the rules, [RU SHIP Pt.3 Ch.4 Sec.7 Table 1](#). Internal pressures include static dry and liquid cargo, ballast and other liquid pressure, setting pressure on relief valve and dynamic pressure of dry and liquid cargo, ballast and other liquid pressure due to acceleration.

5.4 Other loads

Application of specific load for some ship types are given in relevant Class Guidelines. For instance, the application of a container forces is given in [DNVGL-CG-0131 Container ships](#).

6 Hull girder loads

6.1 General

6.1.1 Hull girder loads in partial ship FE analysis

As partial ship FE model represents a part of the ship, the local loads (i.e. static and dynamic internal and external loads) applied to the model will induce hull girder loads which represent a semi-global effect. The semi global effect may not necessarily reach desired hull girder loads, i.e. hull girder targets. The procedures as given in [\[6.3\]](#) and [\[6.4\]](#) describe hull girder adjustments to the targets as defined in [\[6.2\]](#) by applying additional forces and moments to the model.

The adjustments are calculated and each hull girder component can be adjusted separately, i.e.:

- Hull girder vertical shear force.
- Hull girder vertical bending moment.
- Hull girder horizontal bending moment.
- Hull girder torsional moment.

6.1.2 Application

Hull girder targets and the procedures for hull girder adjustments given in this Section are applicable for a three cargo hold length FE analysis with boundary conditions as given in [\[3\]](#). For ships without cargo hold arrangement or for evaluation areas outside cargo area, the analysis procedures given in this chapter may be applied with a special consideration.

6.2 Hull girder targets

6.2.1 Target hull girder vertical bending moment

The target hull girder vertical bending moment, M_{v-targ} , in kNm, at a longitudinal position for a given FE load combination is taken as:

$$M_{v-targ} = C_{BM-LC} M_{sw} + M_{wv-LC}$$

where:

C_{BM-LC} = Percentage of permissible still water bending moment applied for the load combination under consideration. When FE load combinations are specified in the rules, [RU SHIP Pt.5](#) for a considered ship type, the factor C_{BM-LC} is given for each loading pattern.

- M_{sw} = Permissible still water bending moments at the considered longitudinal position for seagoing and harbour conditions as defined in the rules, [RU SHIP Pt.3 Ch.4 Sec.4 \[2.2.2\]](#) and respectively. M_{sw} is either in sagging or in hogging condition. When FE load combinations are specified in the rules, [RU SHIP Pt.5](#) for a considered ship type, the condition (sagging or hogging) is given for each FE load combination.
- M_{wv-LC} = Vertical wave bending moment in kNm, for the dynamic load case under consideration, calculated in accordance with in the rules, [RU SHIP Pt.3 Ch.4 Sec.4 \[3.5.2\]](#).

The values of M_{v-targ} are taken as:

- Midship cargo hold region: the maximum hull girder bending moment within the mid-hold(s) of the model.
- Outside midship cargo hold region: the values of all web frame and transverse bulkhead positions of the FE model under consideration.

6.2.2 Target hull girder shear force

The target hull girder vertical shear force at the aft and forward transverse bulkheads of the mid-hold, $Q_{targ-aft}$ and $Q_{targ-fwd}$, in kN, for a given FE load combination is taken as:

- $Q_{fwd} \geq Q_{aft}$:

$$Q_{targ-aft} = C_{SF-LC} \cdot Q_{sw-neg} - \Delta Q_{swa} + f_{\beta} |C_{QW}| Q_{wv-neg}$$

$$Q_{targ-fwd} = C_{SF-LC} \cdot Q_{sw-pos} + \Delta Q_{swf} + f_{\beta} |C_{QW}| Q_{wv-pos}$$

- $Q_{fwd} < Q_{aft}$:

$$Q_{targ-aft} = C_{SF-LC} \cdot Q_{sw-pos} + \Delta Q_{swa} + f_{\beta} |C_{QW}| Q_{wv-pos}$$

$$Q_{targ-fwd} = C_{SF-LC} \cdot Q_{sw-neg} - \Delta Q_{swf} + f_{\beta} |C_{QW}| Q_{wv-neg}$$

where:

- Q_{fwd} Q_{aft} = Vertical shear forces, in kN, due to the local loads respectively at the forward and aft bulkhead position of the mid-hold, as defined in [\[6.3.5\]](#).
- C_{SF-LC} = Percentage of permissible still water shear force. When FE load combinations are specified in the rules, [RU SHIP Pt.5](#) for a considered ship type, the factor C_{SF-LC} is given for each loading pattern.
- Q_{sw-pos} Q_{sw-neg} = Positive and negative permissible still water shear forces, in kN, at any longitudinal position for seagoing and harbour conditions as defined in the rules, [RU SHIP Pt.3 Ch.4 Sec.4 \[2.4.2\]](#).
- ΔQ_{swf} = Shear force correction, in kN, for the considered FE loading pattern at the forward bulkhead taken as minimum of the absolute values of ΔQ_{mdf} as defined in the rules, [RU SHIP Pt.5](#) for relevant ship type, calculated at forward bulkhead for the mid-hold and the value calculated at aft bulkhead of the forward cargo hold taken as:

- For ships, where shear force correction, ΔQ_{mdf} , is required in the rules, [RU SHIP Pt.5](#):

$$\Delta Q_{swf} = \text{Min}(|\Delta Q_{mdf}|_{Mid}, |\Delta Q_{mdf}|_{Fwd})$$

- Otherwise:

$$\Delta Q_{swf} = 0$$

ΔQ_{swa} = Shear force correction, in kN, for the considered FE loading pattern at the aft bulkhead taken as Minimum of the absolute values of ΔQ_{mdf} as defined in the rules, [RU SHIP Pt.5](#) for relevant ship type calculated at forward bulkhead for the mid-hold and the value calculated at aft bulkhead of the forward cargo hold taken as:

- For ships, where shear force correction, ΔQ_{mdf} , is required in the rules, [RU SHIP Pt.5](#):

$$\Delta Q_{swa} = \text{Min}(|\Delta Q_{mdf}|_{Mid}, |\Delta Q_{mdf}|_{Aft})$$

- Otherwise:

$$\Delta Q_{swf} = 0$$

f_{β} = Wave heading factor, as given in rules, [RU SHIP Pt.3 Ch.4 Sec.4](#).
 C_{QW} = Load combination factor for vertical wave shear force, as given in rules, [RU SHIP Pt.3 Ch.4 Sec.2](#).
 Q_{wv-pos}, Q_{wv-neg} = Positive and negative vertical wave shear force, in kN, as defined in rules, [RU SHIP Pt.3 Ch.4 Sec.4 \[3.2.1\]](#).

6.2.3 Target hull girder horizontal bending moment

The target hull girder horizontal bending moment, M_{h-targ} , in kNm, for a given FE load combination is taken as:

$$M_{h-targ} = M_{wh-LC}$$

where:

M_{wh-LC} = Horizontal wave bending moment, in kNm, for the dynamic load case under consideration, calculated in accordance with in the rules, [RU SHIP Pt.3 Ch.4 Sec.4 \[3.5.4\]](#).

The values of M_{wh-LC} are taken as:

- Midship cargo hold region: the value calculated for the middle of the individual cargo hold under consideration.
- Outside midship cargo hold region: the values calculated at all web frame and transverse bulkhead positions of the FE model under consideration.

6.2.4 Target hull girder torsional moment

The target hull girder torsional moment, $M_{wt-targ}$, in kNm, for the dynamic load cases OST and OSA is the value at the target location taken as:

$$M_{wt-targ} = M_{wt-LC}(x_{targ})$$

where:

$M_{wt-LC}(x)$ = Wave torsional moment, in kNm, for the dynamic load case OST and OSA, defined in [RU SHIP Pt.3 Ch.4 Sec.4 \[3.5.5\]](#), calculated at x position.

x_{targ} = Target location for hull girder torsional moment taken as:

- For midship cargo hold region:
 - If $x_{mid} \leq 0.531 L$: after bulkhead of the mid-hold.
 - If $x_{mid} > 0.531 L$: forward bulkhead of the mid-hold.
- Outside midship cargo hold region:
 - The transverse bulkhead of mid-hold where the following formula is minimum:

$$\frac{M_{wt-LC}(x_{bhd})}{|M_{wt-LC}(x_{bhd})|} \cdot [M_{wt-LC}(x_{bhd}) - M_{T-FEM}(x_{bhd})]$$

x_{mid} = X-coordinate, in m, of the mid-hold centre.

x_{bhd} = X-coordinate, in m, of the after or forward transverse bulkhead of mid-hold.

The target hull girder torsional moment, $M_{wt-targ}$, is required for the dynamic load case OST and OSA of relevant ship types as specified in the rules, [RU SHIP Pt.5](#). Normally, hull girder torsional moment are to be considered for ships with large deck openings subjected to overall torsional deformation and stress response. For other dynamic load cases or for other ships where hull girder torsional moment, $M_{wt-targ}$, is to be adjusted to zero at middle of mid-hold.

6.3 Procedure to adjust hull girder shear forces and bending moments

6.3.1 General

This procedure describes how to adjust the hull girder horizontal bending moment, vertical force and vertical bending moment distribution on the three cargo hold FE model to achieve the required target values at required locations. The hull girder load target values are specified in [\[6.2\]](#). The target locations for hull girder shear force are at the transverse bulkheads of the mid-hold of the FE model. The final adjusted hull girder shear force at the target location should not exceed the target hull girder shear force. The target location for hull girder bending moment is, in general, located at the centre of the mid-hold of the FE model. If the maximum value of bending moment is not located at the centre of the mid-hold, the final adjusted maximum bending moment shall be located within the mid-hold and is not to exceed the target hull girder bending moment.

6.3.2 Local load distribution

The following local loads are to be applied for the calculation of hull girder shear and bending moments:

- a) Ship structural steel weight distribution over the length of the cargo hold model (static loads).
- b) Weight of cargo and ballast (static loads).
- c) Static sea pressure, dynamic wave pressure and, where applicable, green sea load. For the harbour/tank testing load cases, only static sea pressure needs to be applied.
- d) Dynamic cargo and ballast loads for seagoing load cases.

With the above local loads applied to the FE model, the FE nodal forces are obtained through FE loading procedure. The 3D nodal forces will then be lumped to each longitudinal station to generate the one dimension local load distribution. The longitudinal stations are located at transverse bulkheads/frames and typical longitudinal FE model nodal locations in between the frames according to the cargo hold model mesh size requirement. Any intermediate nodes created for modelling structural details are not treated as the

longitudinal stations for the purpose of local load distribution. The nodal forces within half of forward and half of afterward of longitudinal station spacing are lumped to that station. The lumping process will be done for vertical and horizontal nodal forces separately to obtain the lumped vertical and horizontal local loads, f_{vi} and f_{hi} , at the longitudinal station i .

6.3.3 Hull girder forces and bending moment due to local loads

With the local load distribution, the hull girder load longitudinal distributions are obtained by assuming the model is simply supported at model ends. The reaction forces at both ends of the model and longitudinal distributions of hull girder shear forces, and bending moments induced by local loads at any longitudinal station, are determined by the following formulae:

$$R_{V-fore} = \frac{\sum_i (x_i - x_{aft}) f_{vi}}{x_{fore} - x_{aft}}$$

$$R_{V-aft} = \sum_i f_{vi} + R_{V-fore}$$

$$R_{H-fore} = \frac{\sum_i (x_i - x_{aft}) f_{hi}}{x_{fore} - x_{aft}}$$

$$R_{H-aft} = -\sum_i f_{hi} + R_{H-fore}$$

$$F_l = \sum_i f_{li}$$

$$Q_{V_FEM}(x_j) = R_{V-aft} - \sum_i f_{vi}$$

when $x_i < x_j$

$$Q_{H_FEM}(x_j) = R_{H-aft} - \sum_i f_{hi}$$

when $x_i < x_j$

$$M_{V_FEM}(x_j) = (x_j - x_{aft}) R_{V-aft} - \sum_i (x_j - x_i) f_{vi}$$

when $x_i < x_j$

$$M_{H_FEM}(x_j) = (x_j - x_{aft}) R_{H-aft} - \sum_i (x_j - x_i) f_{hi}$$

when $x_i < x_j$

where:

R_{V-afb} R_{V-fore} R_{H-afb} R_{H-fore} = Vertical and horizontal reaction forces at the aft and fore ends.

X_{aft}^{fore}

= X-coordinate of the aft end support, in m.

x_{fore}

= X-coordinate of the fore end support, in m.

f_{yi}

= Lumped vertical local load at longitudinal station i as defined in [6.3.2], in kN.

f_{hi}

= Lumped horizontal local load at longitudinal station i as defined in [6.3.2], in kN.

F_l

= Total net longitudinal force of the model, in kN.

f_{li}

= Lumped longitudinal local load at longitudinal station i as defined in [6.3.2], in kN.

x_j

= X-coordinate, in m, of considered longitudinal station j .

x_i

= X-coordinate, in m, of longitudinal station i .

$Q_{V_FEM}(x_j)$, $Q_{H_FEM}(x_j)$,

= Vertical and horizontal shear forces, in kN, and bending moments, in kNm, at

$M_{V_FEM}(x_j)$, $M_{H_FEM}(x_j)$

longitudinal station x_j created by the local loads applied on the FE model. The sign convention for reaction forces is that a positive bending moment creates a positive shear force.

6.3.4 Longitudinal unbalanced force

In case total net longitudinal force of the model, F_l , is not equal to zero, the counter longitudinal force, $(F_x)_j$, is to be applied at one end of the model, where the translation on X-direction, δ_x , is fixed, by distributing longitudinal axial nodal forces to all hull girder bending effective longitudinal elements, as follows:

$$(F_x)_j = \frac{F_l}{A_x} \frac{A_j}{n_j}$$

where:

$(F_x)_j$

= Axial force applied to a node of the j -th element, in kN.

F_l

= Total net longitudinal force of the model, as defined in [6.3.3], in kN.

A_j

= Cross sectional area of the j -th element, in m^2 .

A_x

= Cross sectional area of fore end section, in m^2 ,

$$A_x = \sum_j A_j$$

n_j

= Number of nodal points of j -th element on the cross section, $n_j = 1$ for beam element, $n_j = 2$ for 4-node shell element.

6.3.5 Hull girder shear force adjustment procedure

The two following methods are to be used for the shear force adjustment:

- Method 1 (M1): for shear force adjustment at one bulkhead of the mid-hold as given in [6.3.6],
- Method 2 (M2): for shear force adjustment at both bulkheads of the mid-hold as given in [6.3.7].

For the considered FE load combination, the method to be applied is to be selected as follows:

- For maximum shear force load combination (Max SFLC), the method 1 applies at the bulkhead given in Table 6, if the shear force after the adjustment with method 1 at the other bulkhead does not exceed the target value. Otherwise, the method 2 applies.
- For other FE load combination:
 - The shear force adjustment is not requested when the shear forces at both bulkheads are lower or equal to the target values.

- The method 1 applies when the shear force exceeds the target at one bulkhead and the shear force at the other bulkhead after the adjustment with method 1 does not exceed the target value. Otherwise the method 2 applies,
- The method 2 applies when the shear forces at both bulkheads exceed the target values,

When FE load combinations are specified in the rules, [RU SHIP Pt.5](#) for a considered ship type, the "maximum shear force load combination" are marked as "Max SFLC" in the FE load combination tables. The "other shear force load combinations" are those which are not the maximum shear force load combinations.

Table 6 Mid-hold bulkhead location for shear force adjustment

Design loading conditions	Bulkhead location	M_{WV-LC}	Condition on Q_{fwd}	Mid-hold bulkhead for SF adjustment
Seagoing conditions	$x_{b-aft} > 0.5 L$	< 0 (sagging)	$Q_{fwd} > Q_{aft}$	Fwd
			$Q_{fwd} \leq Q_{aft}$	Aft
		> 0 (hogging)	$Q_{fwd} > Q_{aft}$	Aft
			$Q_{fwd} \leq Q_{aft}$	Fwd
	$x_{b-fwd} < 0.5 L$	< 0 (sagging)	$Q_{fwd} > Q_{aft}$	Aft
			$Q_{fwd} \leq Q_{aft}$	Fwd
		> 0 (hogging)	$Q_{fwd} > Q_{aft}$	Fwd
			$Q_{fwd} \leq Q_{aft}$	Aft
$x_{b-aft} \leq 0.5 L$ and $x_{b-fwd} \geq 0.5 L$	-	-	(1)	
Harbour and testing conditions	whatever the location	-	-	(1)

1) No limitation of Mid-hold bulkhead location for shear force adjustment. In this case the shear force can be adjusted to the target either at forward (Fwd) or at aft (Aft) mid hold bulkhead.

6.3.6 Method 1 for shear force adjustment at one bulkhead

The required adjustments in shear force at following transverse bulkheads of the mid-hold are given by:

- Aft bulkhead:

$$M_{Y_{aft}} = M_{Y_{fore}} = \frac{(x_{fore} - x_{aft})}{2} (Q_{targ-aft} - Q_{aft})$$

- Forward bulkhead:

$$M_{Y_{aft}} = M_{Y_{fore}} = \frac{(x_{fore} - x_{aft})}{2} (Q_{targ-fwd} - Q_{fwd})$$

Where:

- $M_{Y_{aft}_0}, M_{Y_{fore}_0}$ = Vertical bending moment, in kNm, to be applied at the aft and fore ends in accordance with [6.3.10], to enforce the hull girder vertical shear force adjustment as shown in Table 7. The sign convention is that of the FE model axis.
- Q_{aft} = Vertical shear force, in kN, due to local loads at aft bulkhead location of mid-hold, x_{b-aft} , resulting from the local loads calculated according to [6.3.5].
 Since the vertical shear force is discontinued at the transverse bulkhead location, Q_{aft} is the maximum absolute shear force between the stations: located right after and right forward of the aft bulkhead of mid-hold.
- Q_{fwd} = Vertical shear force, in kN, due to local loads at the forward bulkhead location of mid-hold, x_{b-fwd} , resulting from the local loads calculated according to [6.3.5].
 Since the vertical shear force is discontinued at the transverse bulkhead location, Q_{fwd} is the maximum absolute shear force between the stations located right after and right forward of the forward bulkhead of mid-hold.

Table 7 Vertical shear force adjustment by application of vertical bending moments $M_{Y_{aft}}$ and $M_{Y_{fore}}$ for method 1

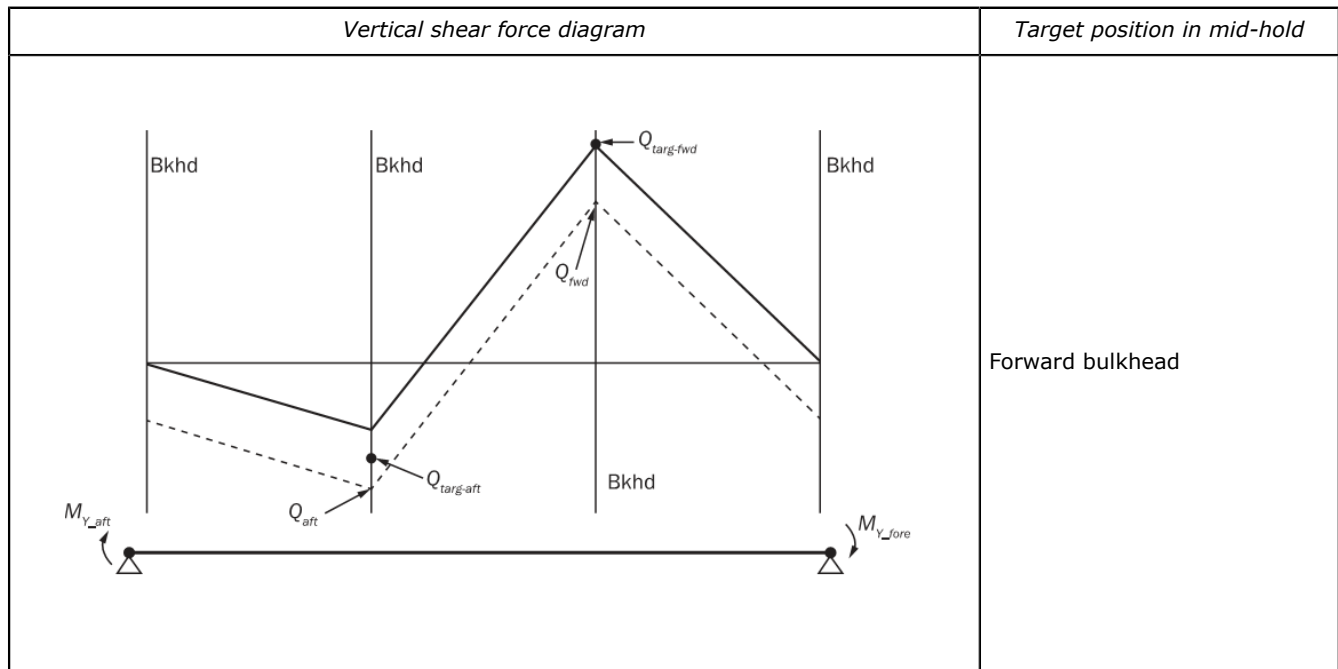

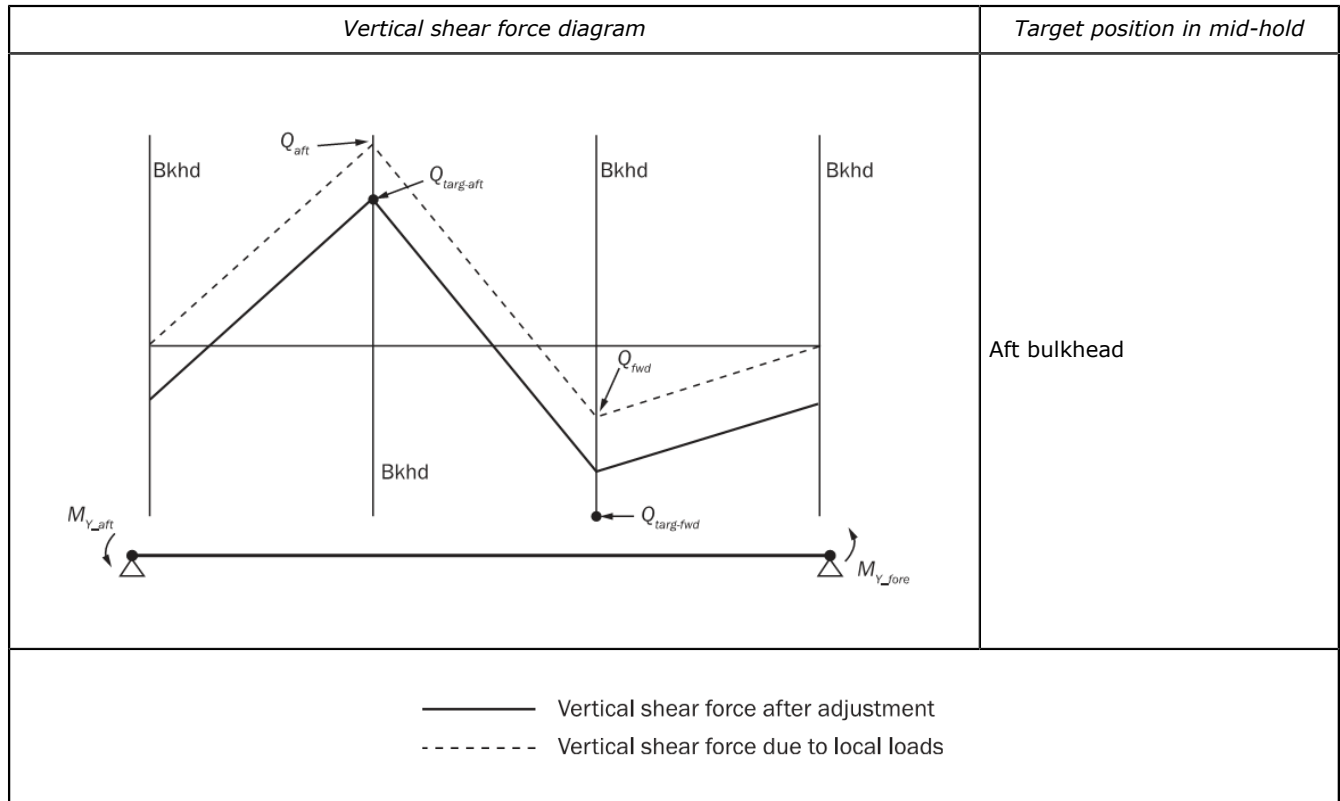

6.3.7 Method 2 for vertical shear force adjustment at both bulkheads

The required adjustments in shear force at both transverse bulkheads of the mid-hold are to be made by applying:

- Vertical bending moments, M_{Y_aft} , M_{Y_fore} at model ends and,
- Vertical loads at the transverse frame positions as shown in Table 9 in order to generate vertical shear forces, ΔQ_{aft} and ΔQ_{fwd} , at the transverse bulkhead positions.

Table 8 shows examples of the shear adjustment application due to the vertical bending moments and to vertical loads.

$$M_{Y_aft} = \frac{x_{fore} - x_{aft}}{2} \cdot \frac{Q_{targ-fwd} - Q_{fwd} + Q_{targ-aft} - Q_{aft}}{2}$$

$$\Delta Q_{fwd} = \frac{Q_{targ-fwd} - Q_{fwd} - (Q_{targ-aft} - Q_{aft})}{2}$$

$$M_{Y_fore} = M_{Y_aft}$$

$$\Delta Q_{aft} = -\Delta Q_{fwd}$$

Where:

- $M_{Y_{aft}}$ $M_{Y_{fore}}$ = Vertical bending moment, in kNm, to be applied at the aft and fore ends in accordance with [6.3.10], to enforce the hull girder vertical shear force adjustment. The sign convention is that of the FE model axis.
- ΔQ_{aft} = Adjustment of shear force, in kN, at aft bulkhead of mid-hold.
- ΔQ_{fwd} = Adjustment of shear force, in kN, at fore bulkhead of mid-hold.

The above adjustments in shear forces, ΔQ_{aft} and ΔQ_{fwd} , at the transverse bulkhead positions are to be generated by applying vertical loads at the transverse frame positions as shown in Table 9. For bulk carriers, the transverse frame positions correspond to the floors. Vertical correction loads are not to be applied to any transverse tight bulkheads, any frames forward of the forward cargo hold and any frames aft of the aft cargo hold of the FE model.

The vertical loads to be applied to each transverse frame to generate the increase/decrease in shear force at the bulkheads may be calculated as shown in Table 9. In case of uniform frame spacing, the amount of vertical force to be distributed at each transverse frame may be calculated in accordance with Table 10.

Table 8 Target and required shear force adjustment by applying vertical forces

Vertical shear force diagram	Aft Bhd	Fore Bhd
	SF target	SF target
	$Q_{targ-aft}$ (-ve)	$Q_{targ-fwd}$ (+ve)

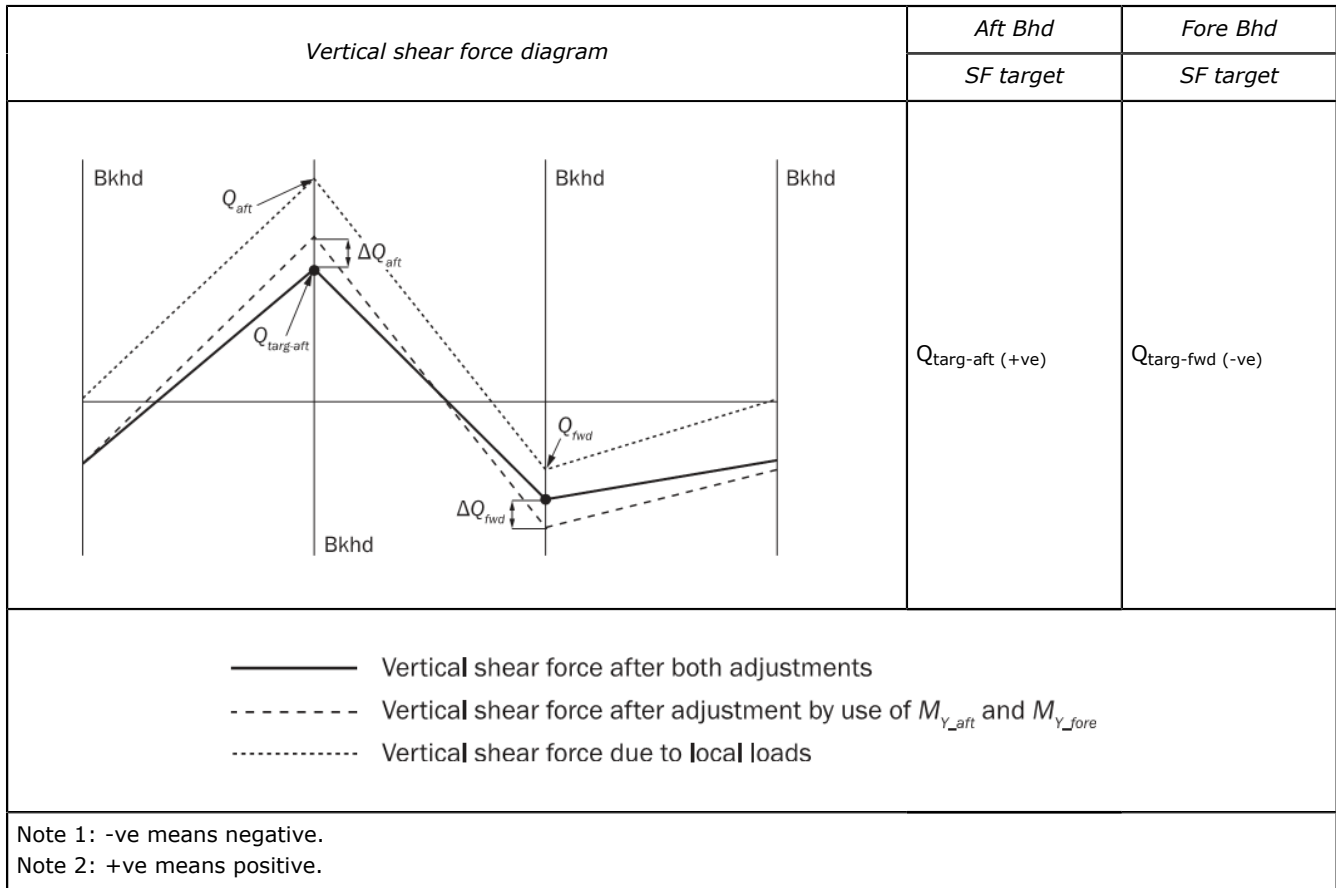
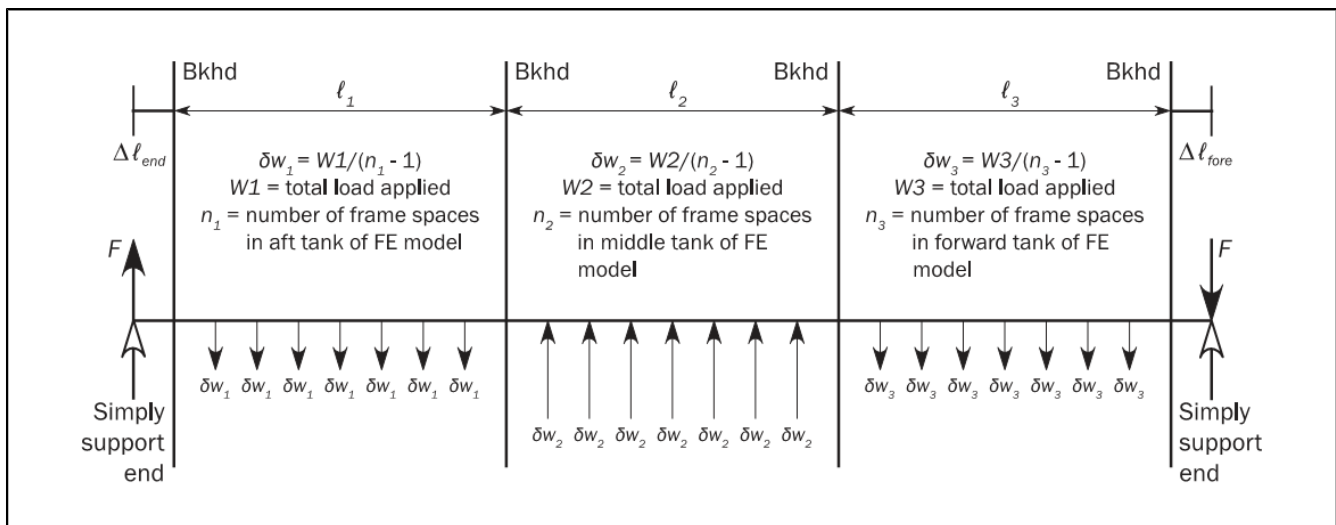
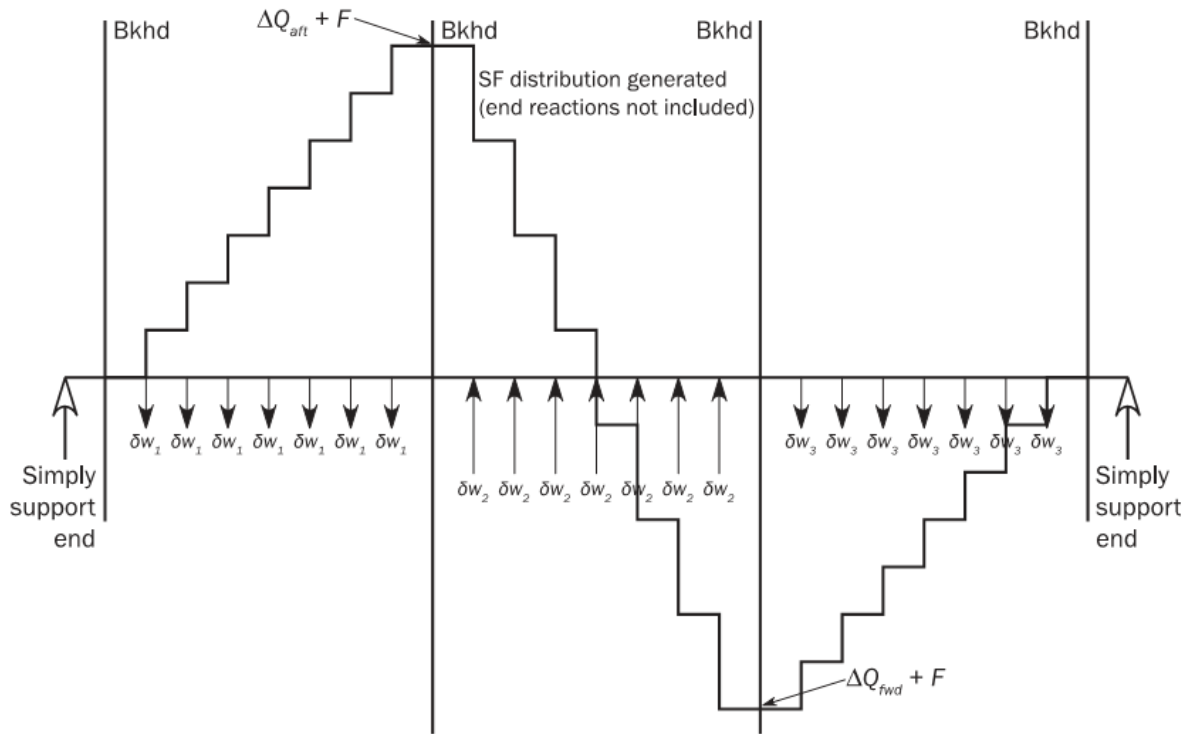

Table 9 Distribution of adjusting vertical force at frames and resulting shear force distributions



Note:

- Transverse bulkhead frames not loaded
- Frames beyond aft transverse bulkhead of aft most hold, and forward bulkhead of forward most hold, not loaded
- F = Reaction load generated by supported ends



Shear Force distribution due to adjusting vertical force at frames

Note: For the definitions of symbols, see [Table 10](#)

Table 10 Table 3-8 Formulae for calculation of vertical loads for adjusting vertical shear forces

$\delta w_1 = \frac{\Delta Q_{aft}(2\ell - \ell_2 - \ell_3) + \Delta Q_{fwd}(\ell_2 + \ell_3)}{(n_1 - 1)(2\ell - \ell_1 - 2\ell_2 - \ell_3)}$	$F = 0.5 \left(\frac{W_1(\ell_2 + \ell_1) - W_3(\ell_2 + \ell_3)}{\ell} \right)$
$\delta w_2 = \frac{(W_1 + W_3)}{(n_2 - 1)} = \frac{(\Delta Q_{aft} - \Delta Q_{fwd})}{(n_2 - 1)}$	
$\delta w_3 = \frac{-\Delta Q_{fwd}(2\ell - \ell_1 - \ell_2) - \Delta Q_{aft}(\ell_1 + \ell_2)}{(n_3 - 1)(2\ell - \ell_1 - 2\ell_2 - \ell_3)}$	
<p>where:</p> <ul style="list-style-type: none"> ℓ_1 = Length of aft cargo hold of model, in m. ℓ_2 = Length of mid-hold of model, in m. ℓ_3 = Length of forward cargo hold of model, in m. ΔQ_{aft} = Required adjustment in shear force, in kN, at aft bulkhead of middle hold, see [6.3.7]. ΔQ_{fwd} = Required adjustment in shear force, in kN, at fore bulkhead of middle hold, see [6.3.7]. F = End reactions, in kN, due to application of vertical loads to frames. W_1 = Total evenly distributed vertical load, in kN, applied to aft hold of FE model, $(n_1 - 1) \delta w_1$. W_2 = Total evenly distributed vertical load, in kN, applied to mid-hold of FE model, $(n_2 - 1) \delta w_2$. W_3 = Total evenly distributed vertical load, in kN, applied to forward hold of FE model, $(n_3 - 1) \delta w_3$. n_1 = Number of frame spaces in aft cargo hold of FE model. n_2 = Number of frame spaces in mid-hold of FE model. n_3 = Number of frame spaces in forward cargo hold of FE model. δw_1 = Distributed load, in kN, at frame in aft cargo hold of FE model. δw_2 = Distributed load, in kN, at frame in mid-hold of FE model. δw_3 = Distributed load, in kN, at frame in forward cargo hold of FE model. Δl_{end} = Distance, in m, between end bulkhead of aft cargo hold to aft end of FE model. Δl_{fore} = Distance, in m, between fore bulkhead of forward cargo hold to forward end of FE model. ℓ = Total length, in m, of FE model including portions beyond end bulkheads: = $l_1 + l_2 + l_3 + \Delta l_{end} + \Delta l_{fore}$ 	
<p>Note 1: Positive direction of loads, shear forces and adjusting vertical forces in the formulae is in accordance with Table 8 and Table 9.</p> <p>Note 2: $W_1 + W_3 = W_2$.</p> <p>Note 3: The above formulae are only applicable if uniform frame spacing is used within each hold. The length and frame spacing of individual cargo holds may be different.</p>	

If non-uniform frame spacing is used within each cargo hold, the average frame spacing ℓ_{av-i} is used to calculate the average distributed frame loads δw_{av-i} , according to [Table 9](#), where $i = 1, 2, 3$ for each hold. Then δw_{av-i} is redistributed to the non-uniform frame as follows:

$$\delta w_i^k = \delta w_{av-i} \frac{\ell_{av-i}^k}{\ell_{av-i}} \quad k=1, 2, \dots, n_i - 1, \text{ for each frame in cargo hold } i, i=1, 2, 3$$

where:

- ℓ_{av-i} = Average frame spacing, in m, calculated as ℓ_i/n_i , in cargo hold i with $i = 1, 2, 3$.
 ℓ_i = Length, in m, of the cargo hold i with $i = 1, 2, 3$ as defined in Table 9.
 n_i = Number of frame spacing in cargo hold i with $i = 1, 2, 3$ as defined in Table 10.
 δw_{av-i} = Average uniform frame spacing, in m, distributed force calculated according to Table 9 with the average frame spacing ℓ_{av-i} in cargo hold i with $i = 1, 2, 3$.
 δw_i^k = Distributed load, in kN, for non-uniform frame k in cargo hold i .
 ℓ_{av-i}^k = Equivalent frame spacing, in m, for each frame k with $k = 1, 2, \dots, n_i - 1$, in cargo hold i , taken as:

$$I_{av-i}^k = \ell_i^1 - \frac{\ell_{av-i} \ell_i^1}{\ell_i^1 + \ell_i^{n_i}} + \frac{\ell_i^2}{2} \quad \text{for } k = 1 \text{ (first frame), in cargo hold } i$$

$$I_{av-i}^k = \frac{\ell_i^k}{2} + \frac{\ell_i^{k+1}}{2} \quad \text{for } k = 2, 3, \dots, n_i-2, \text{ in cargo } i$$

$$I_{av-i}^k = \ell_i^{n_i} - \frac{\ell_{av-i} \ell_i^{n_i}}{\ell_i^1 + \ell_i^{n_i}} + \frac{\ell_i^{n_i-1}}{2} \quad \text{for } k = n_i-1 \text{ (last frame), in cargo } i$$

- ℓ_i^k = Frame spacing, in m, between the frame $k - 1$ and k in the cargo hold i :
 The required vertical load δw_i for a uniform frame spacing or δw_i^k for non-uniform frame spacing, are to be applied by following the shear flow distribution at the considered cross section. For a frame section under vertical load δw_i , the shear flow, q_f , at the middle point of the element is calculated as:

$$q_{f-k} = \frac{\delta w_i}{I_y} Q_k$$

- q_{f-k} = Shear flow calculated at the middle of the k -th element of the transverse frame, in N/mm.
 δw_i = Distributed load at each transverse frame location for i -th cargo hold, $i = 1, 2, 3$, as defined in Table 10, in N.
 I_y = Moment of inertia of the hull girder cross section, in mm⁴.
 Q_k = First moment about neutral axis of the accumulative section area starting from the open end (shear stress free end) of the cross section to the point s_k for shear flow q_{f-k} , in mm³, taken as:

$$Q_k = \int_0^{s_k} z_{neu} t ds$$

- z_{neu} = Vertical distance from the integral point, s , to the vertical neutral axis.

t = Thickness, in mm, of the plate at the integral point of the cross section.
The distributed shear force at j -th FE grid of the transverse frame, F_{j-grid} , is obtained from the shear flow of the connected elements as following:

$$F_{j-grid} = \sum_{k=1}^n q_{f-k} \frac{\ell_k}{2}$$

l_k = Length of the k -th element of the transverse frame connected to the grid j , in mm.
 n = Total number of elements connect to the grid j .

The shear flow has direction along the cross section and therefore the distributed force, F_{j-grid} , is a vector force. For vertical hull girder shear correction, the vertical and horizontal force components calculated with above mentioned shear flow method above need to be applied to the cross section.

6.3.8 Procedure to adjust vertical and horizontal bending moments for midship cargo hold region

In case the target vertical bending moment needs to be reached, an additional vertical bending moment is to be applied at both ends of the cargo hold FE model to generate this target value in the mid-hold of the model. This end vertical bending moment is given as follows:

$$M_{v-end} = M_{v-targ} - M_{v-peak}$$

where:

M_{v-end} = Additional vertical bending moment, in kNm, to be applied to both ends of FE model in accordance with [6.3.10].
 M_{v-targ} = Hogging (positive) or sagging (negative) vertical bending moment, in kNm, as specified in [6.2.1].
 M_{v-peak} = Maximum or minimum bending moment, in kNm, within the length of the mid-hold due to the local loads described in [6.3.3] and due to the shear force adjustment as defined in [6.3.5].
 M_{v-peak} is to be taken as the maximum bending moment if M_{v-targ} is hogging (positive) and as the minimum bending moment if M_{v-targ} is sagging (negative). M_{v-peak} is to be calculated as based on the following formula:

$$M_{v-peak} = \left\{ M_{V-FEM}(x) + M_{lineload} + M_{Y_{aft}} \left(2 \frac{x - x_{aft}}{x_{fore} - x_{aft}} - 1 \right) \right\}$$

$M_{V-FEM}(x)$ = Vertical bending moment, in kNm, at position x , due to the local loads as described in [6.3.3].
 $M_{Y_{aft}}$ = End bending moment, in kNm, to be taken as:
— When method 1 is applied: the value as defined in [6.3.6].
— When method 2 is applied: the value as defined in [6.3.7].
— Otherwise: $M_{Y_{aft}} = 0$
 $M_{lineload}$ = Vertical bending moment, in kNm, at position x , due to application of vertical line loads at frames according to method 2, to be taken as:

$$M_{lineload} = (x - x_{aft})F - \sum_i (x - x_i)\delta w_i$$

- F = Reaction force, in kN, at model ends due to application of vertical loads to frames as defined in [Table 10](#).
- x = X-coordinate, in m, of frame in way of the mid-hold.
- x_{aft} = X-coordinate at aft end support, in mm
- x_{fore} = X-coordinate at fore end support, in mm
- δw_i = vertical load, in kN, at web frame station i applied to generate required shear force.

In case the target horizontal bending moment needs to be reached, an additional horizontal bending moment is to be applied at the ends of the cargo tank FE model to generate this target value within the mid-hold. The additional horizontal bending moment is to be taken as:

$$M_{h-end} = M_{h-targ} - M_{h-peak}$$

where:

- M_{h-end} = Additional horizontal bending moment, in kNm, to be applied to both ends of the FE model according to [\[6.3.10\]](#).
- M_{h-targ} = Horizontal bending moment, as defined in [\[6.3.2\]](#).
- M_{h-peak} = Maximum or minimum horizontal bending moment, in kNm, within the length of the mid-hold due to the local loads described in [\[6.3.3\]](#).
- M_{h-peak} is to be taken as the maximum horizontal bending moment if M_{h-targ} is positive (starboard side in tension) and as the minimum horizontal bending moment if M_{h-targ} is negative (port side in tension).
- M_{h-peak} is to be calculated as follows based on a simply supported beam model:
- M_{h-peak} = Extremum $\{M_{H_FEM}(x)\}$
- $M_{H_FEM}(x)$ = Horizontal bending moment, in kNm, at position x , due to the local loads as described in [\[6.3.3\]](#).

The vertical and horizontal bending moments are to be calculated over the length of the mid-hold to identify the position and value of each maximum/minimum bending moment.

6.3.9 Procedure to adjust vertical and horizontal bending moments outside midship cargo hold region.

To reach the vertical hull girder target values at each frame and transverse bulkhead position, as defined in [\[6.2.1\]](#), the vertical bending moment adjustments, m_{vi} , are to be applied at web frames and transverse bulkhead positions of the finite element model, as shown in [Figure 19](#).

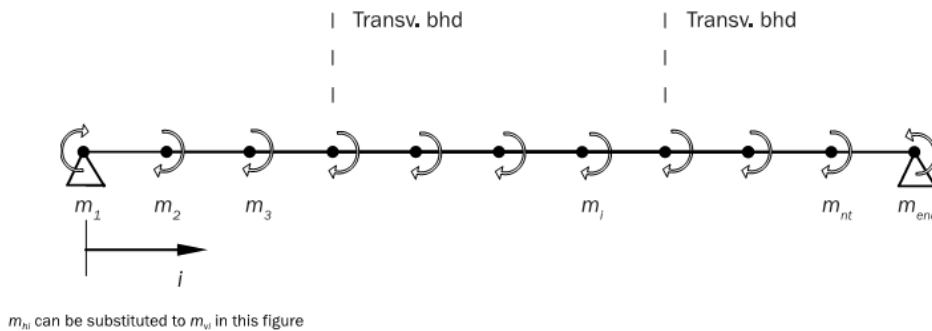

Figure 19 Adjustments of bending moments outside midship cargo hold region.

The vertical bending moment adjustment at each longitudinal location, i , is to be calculated as follows:

$$f(i) = -M_{v-targ}(i) + M_{V-FEM}(i) + M_{lineload}(i) + M_{Y-aft} \cdot \left(2 \cdot \frac{X_i - X_{aft}}{X_{fore} - X_{aft}} - 1 \right)$$

$$m_{vi} = \frac{f(i) + f(i+1)}{2} - \sum_{j=0}^{i-1} m_{vj}$$

$$m_{v_end} = - \sum_{i=0}^{n_t} m_{vj}$$

where:

- i = Index corresponding to the i -th station, starting from $i=1$ at the aft end section up to n_t .
- n_t = Total number of longitudinal stations where the vertical bending moment adjustment, m_{vi} , is applied.
- m_{vi} = Vertical bending moment adjustment, in kNm, to be applied at transverse frame or bulkhead at station i .
- m_{v_end} = Vertical bending moment adjustment, in kNm, to be applied, at the fore end section (n_t+1 station).
- m_{vj} = Argument of summation to be taken as:
 - $m_{vj}=0$ when $j=0$
 - $m_{vj}=m_{vj}$ when $j=i$
- $M_{v-targ}(i)$ = Required target vertical bending moment, in kNm, at station i , calculated in accordance with [RU SHIP Pt.3 Ch.7 Sec.3](#).
- $M_{V-FEM}(i)$ = Vertical bending moment distribution, in kNm, at station i due to local loads as given in [\[6.3.3\]](#).
- $M_{lineload}(i)$ = Vertical bending moment, in kNm, at station i , due to the line load for the vertical shear force correction as required in [\[6.3.7\]](#).

To reach the horizontal hull girder target values at each frame and transverse bulkhead position as defined in [6.3.2], the horizontal bending moment adjustments, m_{hi} , are to be applied at web frames and transverse bulkhead positions of the finite element model, as shown in Figure 19. The horizontal bending moment adjustment at each longitudinal location, i , is to be calculated as follows:

$$f(i) = M_{h-targ}(i) + M_{H-FEM}(i)$$

$$m_{hi} = \frac{(i) + f(i+1)}{2} - \sum_{j=0}^{i-1} m_{hj}$$

$$m_{h_end} = - \sum_{i=0}^{n_t} m_{hj}$$

where:

- i = Longitudinal location for bending moment adjustments, m_{hi} .
- n_t = Total number of longitudinal stations where the horizontal bending moment adjustment, m_{hi} , is applied.
- m_{hi} = Horizontal bending moment adjustment, in kNm, to be applied at transverse frame or bulkhead at station i .
- m_{h_end} = Horizontal bending moment adjustment, in kNm, to be applied at the fore end section (n_t+1 station).
- m_{hj} = Argument of summation to be taken as:
 - $m_{hj} = 0$ when $j=0$
 - $m_{hj} = m_{hi}$ when $j=i$
- $M_{h-targ}(i)$ = Required target horizontal bending moment, in kNm, at station i , calculated in accordance with [RU SHIP Pt.3 Ch.7 Sec.3](#).
- $M_{H-FEM}(i)$ = Horizontal bending moment distribution, in kNm, at station i due to local loads as given in [\[6.3.3\]](#).

The vertical and horizontal bending moment adjustments, m_{vi} and m_{hi} , are to be applied at all web frames and bulkhead positions of the FE model. The adjustments are to be applied in FE model by distributing longitudinal axial nodal forces to all hull girder bending effective longitudinal elements in accordance with [\[6.3.10\]](#).

6.3.10 Application of bending moment adjustments on the FE model.

The required vertical and horizontal bending moment adjustments are to be applied to the considered cross section of the cargo hold model. This is done by distributing longitudinal axial nodal forces to all hull girder bending effective longitudinal elements of the considered cross section according to the simple beam theory as follows:

- For vertical bending moment:

$$(F_x)_i = \frac{M_v}{I_y} \frac{A_i}{n_i} z_i$$

– For horizontal bending moment:

$$(F_x)_i = \frac{M_h}{I_z} \frac{A_i}{n_i} y_i$$

Where:

- M_v = Vertical bending moment adjustment, in kNm, to be applied to the considered cross section of the model.
- M_h = Horizontal bending moment adjustment, in kNm, to be applied to the considered cross section the ends of the model.
- $(F_x)_i$ = Axial force, in kN, applied to a node of the i -th element.
- I_y = Hull girder vertical moment of inertia, in m^4 , of the considered cross section about its horizontal neutral axis.
- I_z = Hull girder horizontal moment of inertia, in m^4 , of the considered cross section about its vertical neutral axis.
- z_i = Vertical distance, in m, from the neutral axis to the centre of the cross sectional area of the i -th element.
- y_i = Horizontal distance, in m, from the neutral axis to the centre of the cross sectional area of the i -th element.
- A_i = cross sectional area, in m^2 , of the i -th element.
- n_i = Number of nodal points of i -th element on the cross section, $n_i = 1$ for beam element, $n_i = 2$ for 4-node shell element.

For cross sections other than cross sections at the model end, the average area of the corresponding i -th elements forward and aft of the considered cross section is to be used.

6.4 Procedure to adjust hull girder torsional moments

6.4.1 General

This procedure describes how to adjust the hull girder torsional moment distribution on the cargo hold FE model to achieve the target torsional moment at the target location. The hull girder torsional moment target values are given in [6.2.4].

6.4.2 Torsional moment due to local loads

Torsional moment, in kNm, at longitudinal station i due to local loads, M_{T-FEMi} in kNm, is determined by the following formula (see Figure 20):

$$M_{T-FEMi} = \sum_k [f_{hik}(z_{ik} - z_r)] - \sum_k (f_{vik} y_{ik})$$

where:

- M_{T-FEMi} = Lumped torsional moment, in kNm, due to local load at longitudinal station i .
- z_r = Vertical coordinate of torsional reference point, in m:

- For ships with large deck openings such as bulk carrier, ore carrier, container carrier:
 $z_r = 0$
 - For other ships with closed decks:
 $z_r = z_{sc}$, shear centre at the middle of the mid-hold
- f_{hik} = Horizontal nodal force, in kN, of node k at longitudinal station i .
 f_{vik} = Vertical nodal force, in kN, of node k at longitudinal station i .
 y_{ik} = Y-coordinate, in m, of node k at longitudinal station i .
 z_{ik} = Z-coordinate, in m, of node k at longitudinal station i .
 M_{T-FEM0} = Lumped torsional moment, in kNm, due to local load at aft end of the finite element FE model (forward end for foremost cargo hold model), taken as:
- for foremost cargo hold model:
- $$M_{T-FEM0} = \sum_k [f_{h0k}(z_{0k} - z_r)] - \sum_k (f_{v0k}y_{0k}) + R_{H_fwd}(z_{ind} - z_r)$$
- for the other cargo hold models:
- $$M_{T-FEM0} = \sum_k [f_{h0k}(z_{0k} - z_r)] - \sum_k (f_{v0k}y_{0k}) + R_{H_aft}(z_{ind} - z_r)$$
- R_{H_fwd} = Horizontal reaction forces, in kN, at the forward end, as defined in [6.3.3].
 R_{H_aft} = Horizontal reaction forces, in kN, at the aft end, as defined in [6.3.3].
 z_{ind} = Vertical coordinate, in m, of independent point.

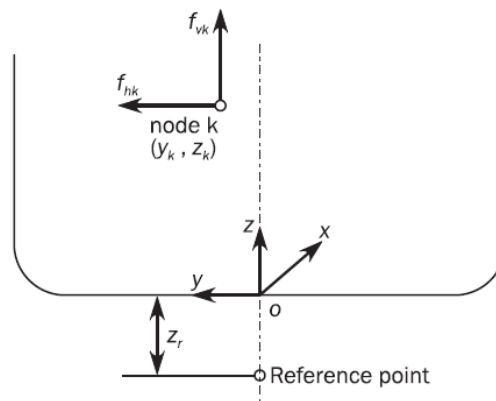

Figure 20 Station forces and acting location of torsional moment at section

6.4.3 Hull girder torsional moment

The hull girder torsional moment, $M_{T-FEM}(x_j)$ in kNm, is obtained by accumulating the torsional moments from the aft end section (forward end for foremost cargo hold model) as follows:

$$M_{T-FEM}(x_j) = \sum_i M_{T-FEMi}$$

- when $x_i \geq x_j$ for foremost cargo hold model,

— when $x_i < x_j$ otherwise.

where:

$M_{T-FEM}(x_j)$ = Hull girder torsional moment, in kNm, at longitudinal station x_j .
 x_j = X-coordinate, in m, of considered longitudinal station j .

The torsional moment distribution given in [6.4.2], has a step at each longitudinal station.

6.4.4 Procedure to adjust hull girder torsional moment to target value

The torsional moment is to be adjusted by applying a hull girder torsional moment M_{T-end} in kNm, at the independent point of the aft end section of the model (forward end for foremost cargo hold model), given as follows:

$$M_{T-end} = M_{wt-targ} - M_{T-FEM}(x_{targ})$$

where:

x_{targ} = X-coordinate, in m, of the target location for hull girder torsional moment, as defined in [6.2.4]
 $M_{wt-targ}$ = Target hull girder torsional moment, in kNm, specified in [6.2.4], to be achieved at the target location.
 $M_{T-FEM}(x_{targ})$ = Hull girder torsional moment, in kNm, at target location due to local loads.

Due to the step of hull girder torsional moment at each longitudinal station, the hull girder torsional moment is to be selected from the values aft and forward of the target location as follows: Maximum value for positive torsional moment and minimum value for negative torsional moment.

6.5 Summary of hull girder load adjustments

The required methods of hull girder load adjustments for different cargo hold regions are given in Table 11.

Table 11 Overview of hull girder load adjustments in cargo hold FE analyses

	<i>Midship cargo hold region</i>	<i>After and Forward cargo hold region</i>	<i>Aft most cargo holds</i>	<i>Foremost cargo holds</i>
Adjustment of Vertical Shear Forces	See [6.3.5]			
Adjustment of Bending Moments	See [6.3.8]	See [6.3.9]		
Adjustment of Torsional Moment	See [6.4.4]			

7 Analysis criteria

7.1 General

7.1.1 Evaluation Area

Yield and buckling strength assessment is to be carried out within the evaluation area of the FE model for all modelled structural members. In the mid-hold cargo analysis, the following structural members shall be evaluated:

- All hull girder longitudinal structural members,
- All primary supporting structural members (web frames, cross ties, etc.), and
- Transverse bulkheads, forward and aft of the mid-hold.

Examples of the longitudinal extent of the evaluation areas for a gas carrier and an ore carrier ships are shown in [Figure 21](#) and [Figure 22](#) respectively.

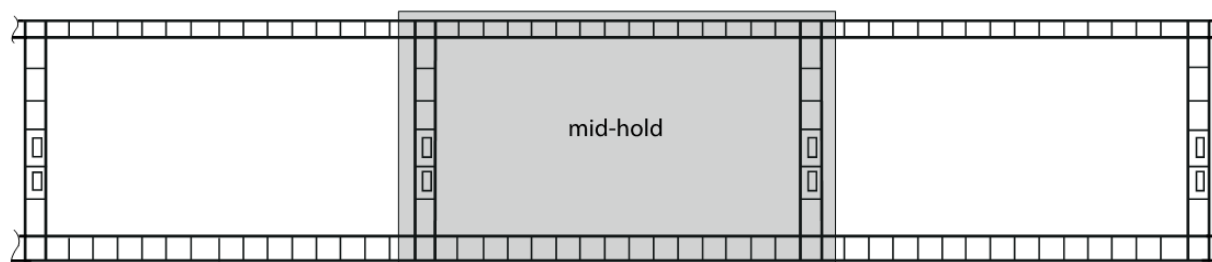

Figure 21 Longitudinal extent of evaluation area for gas carrier

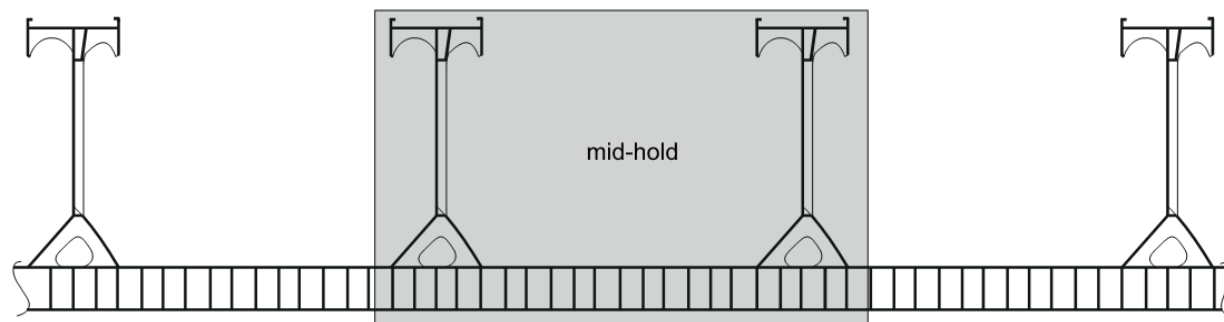

Figure 22 Longitudinal extent of evaluation area for ore carrier

7.1.2 Evaluation areas in fore- and aftmost cargo hold analyses

For the fore- and aftmost cargo hold analysis, the evaluation areas extend to the following structural elements, in addition to elements listed in [\[7.1.1\]](#):

- Foremost Cargo hold:
 - All structural members being part of the collision bulkhead, and extending to one web frame spacing forward of the collision bulkhead,
- Aftmost Cargo hold:

All structural members being part of the transverse bulkhead of the aftmost cargo hold and all hull girder longitudinal structural members aft of this transverse bulkhead with the extent of 15% of the aftmost cargo hold length.

7.2 Yield strength assessment

7.2.1 Von Mises stresses

For all plates of the structural members within evaluation area, the von Mises stress, σ_{vm} , in N/mm^2 , is to be calculated based on the membrane normal and shear stresses of the shell element. The stresses are to be evaluated at the element centroid of the mid-plane (layer), as follows:

$$\sigma_{vm} = \sqrt{\sigma_x^2 - \sigma_x\sigma_y + \sigma_y^2 + 3\tau_{xy}^2}$$

where:

σ_x σ_y = Element normal membrane stresses, in N/mm^2 .
 τ_{xy} = Element shear stress, in N/mm^2 .

In way of cut-outs in webs, the element shear stress, τ_{xy} , is to be corrected for loss in shear area in accordance to the rules, [RU SHIP Pt.3 Ch.7 Sec.3 \[4.2.7\]](#). Alternatively the correction may be carried out by a simplified stress correction as given in the rules, [RU SHIP Pt.3 Ch.7 Sec.3 \[4.2.6\]](#).

7.2.2 Axial stress in beams and rod elements

For beams and rod elements, the axial stress, σ_{axial} , in N/mm^2 , is to be calculated based on axial force alone. The axial stress is to be evaluated at the middle of element length. The axial stress is to be calculated for the following members:

- The flange of primary supporting members,
- The intersections between the flange and web of the corrugations, in dummy rod elements, modelled with unit cross sectional properties at the intersection between the flange and web of the corrugation.

7.2.3 Permissible stress

The coarse mesh permissible yield utilisation factors, λ_{yperm} , given in [\[7.2.4\]](#), are based on the element types and the mesh size described in this section.

Where the geometry cannot be adequately represented in the cargo hold model and the stress exceeds the cargo hold mesh acceptance criteria, a finer mesh may be used for such geometry to demonstrate satisfactory scantlings. If the element size is smaller, stress averaging should be performed. In such cases, the area weighted von Mises stress within an area equivalent to mesh size required for partial ship model is to comply with the coarse mesh permissible yield utilisation factors. Stress averaging is not to be carried across structural discontinuities and abutting structure.

7.2.4 Acceptance criteria - coarse mesh permissible yield utilisation factors

The result from partial ship strength analysis is to demonstrate that the stresses do not exceed the maximum permissible stresses defined as coarse mesh permissible yield utilisation factors, as follows:

$$\lambda_y \leq \lambda_{yperm}$$

where:

λ_y	= Yield utilisation factor
	= $\frac{\sigma_{vm}}{R_y}$ for shell elements in general
	= $\frac{\sigma_{axial}}{R_y}$ for rod or beam elements in general
σ_{vm}	= Von Mises stress, in N/mm ² .
σ_{axial}	= Axial stress in rod element, in N/mm ² .
λ_{yperm}	= Coarse mesh permissible yield utilisation factor, as given in the rules, RU SHIP Pt.3 Ch.7 Sec.3 Table 1 .
R_y	= As defined in the RU SHIP Pt.3 Ch.1 Sec.4 Table 3 .

7.3 Buckling strength assessment

Buckling strength assessment is to be carried out for structural members defined in the rules, [RU SHIP Pt.5](#) for relevant ship type with acceptance criteria given in the rules, [RU SHIP Pt.3 Ch.8 Sec.4](#).

SECTION 4 LOCAL STRUCTURE STRENGTH ANALYSIS

1 Objective and Scope

1.1 General

This section provides procedures for finite element local strength analysis as required by the Rules, [RU SHIP Pt.3 Ch.7 Sec.4](#). Fine mesh FE analysis applies for structural details required by the rules, [RU SHIP Pt.5](#) or optional class notations stated in [RU SHIP Pt.6](#). Such analysis may also be required for other details considered critical.

This section gives general requirements for local strength models. In addition, the procedure for selection of critical locations by screening is described. Class Guidelines for specific ship types may provide additional guidelines.

The analysis is to verify stress levels in the critical locations to be within the acceptable criteria for yielding, as given in [5].

1.2 Modelling of standard structural details

A general description of structural modelling is given in below. In addition, the modelling requirements given in CSR-H, Ch.7 Sec.4 may be used for standard structural details such as:

- hopper knuckles
- frame end brackets
- openings
- connections of deck and double bottom longitudinal stiffeners to transverse bulkhead
- hatch corner area.

2 Structural modelling

2.1 General

2.1.1 The fine mesh analysis may be carried out by means of a separate local finite element model with fine mesh zones, in conjunction with the boundary conditions obtained from the partial ship FE model or Global FE model. Alternatively, fine mesh zones may be incorporated directly into the global or partial ship model.

To ensure same stiffness for the local model and the respective part of the global or partial ship model, the modelling techniques of this guideline shall be applied.

The local models are to be made using shell elements with both bending and membrane properties.

All brackets, web stiffeners and larger openings are to be included in the local models. Structural misalignment and geometry of welds need not to be included.

2.1.2 Model extent

If a separate local fine mesh model is used, its extent is to be such that the calculated stresses at the areas of interest are not significantly affected by the imposed boundary conditions. The boundary of the fine mesh model is to coincide with primary supporting members, such as web frames, girders, stringers or floors.

2.2 Fine mesh zone

2.2.1 General

The fine mesh zone is to represent the localized area of high stress. In this zone, a uniform quadratic mesh is to be used. A smooth transition of mesh density leading up to the fine mesh zone is to be maintained. Examples of fine mesh zones are shown in [Figure 2](#), [Figure 3](#) and [Figure 4](#).

The finite element size within the fine mesh zones is to be not greater than 50 mm x 50 mm. In general, the extent of the fine mesh zone is not to be less than 10 elements in all directions from the area under investigation.

In the fine mesh zone, the use of extreme aspect ratio (e.g. aspect ratio greater than 3) and distorted elements (e.g. element's corner angle less than 60° or greater than 120°) are to be avoided. Also the use of triangular elements is to be avoided

All structural parts within an extent of at least 500 mm in all directions leading up to the high stress area are to be modelled explicitly with shell elements.

Stiffeners within the fine mesh zone are to be modelled using shell elements. Stiffeners outside the fine mesh zones may be modelled using beam elements. The transition between shell elements and beam elements is to be modelled so that the overall stiffener deflection is remained. The overlap beam element can be applied as shown in [Figure 1](#).

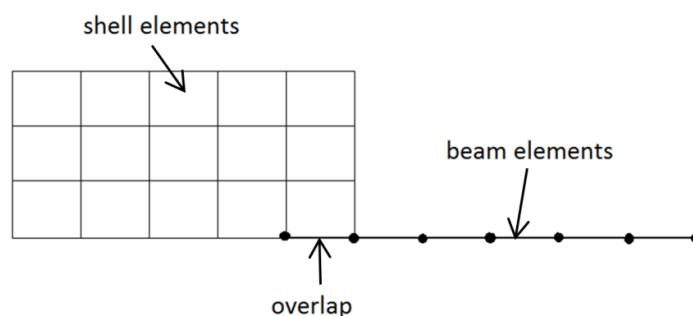

Figure 1 Overlap beam element in the transition between shell elements and beam elements representing stiffeners

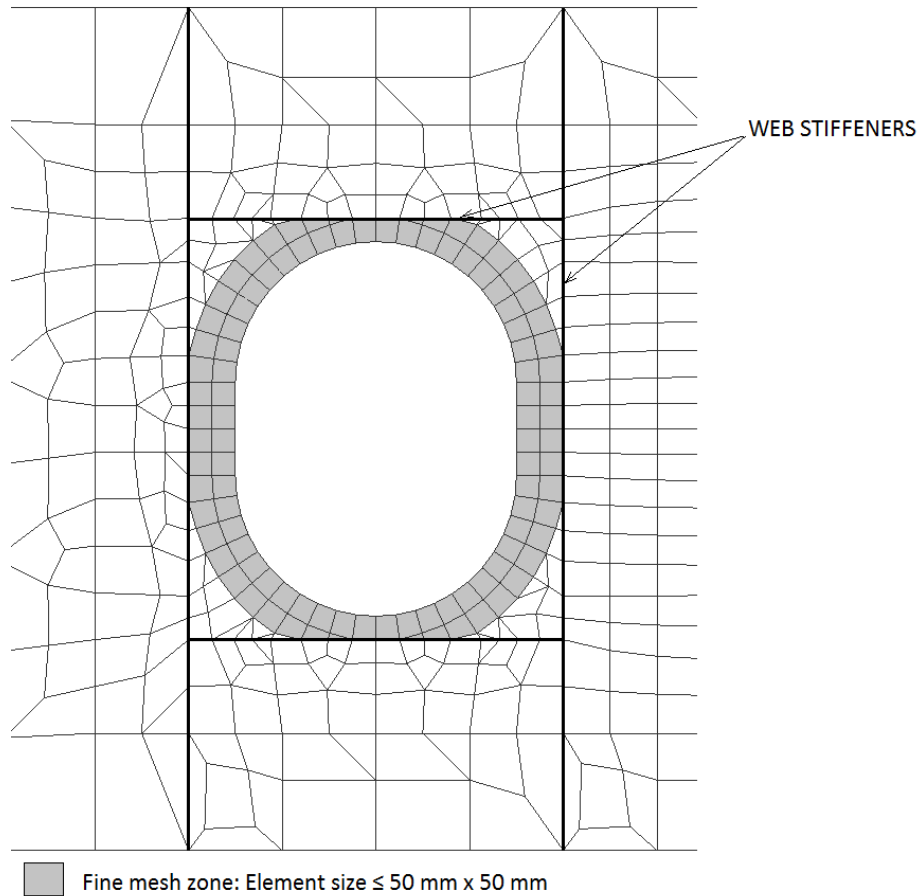

Figure 2 Fine mesh zone around an opening

2.2.2 Openings

Where fine mesh analysis is required for an opening, the first two layers of elements around the opening are to be modelled with mesh size not greater than 50 mm × 50 mm.

Edge stiffeners welded directly to the edge of an opening are to be modelled with shell elements. Web stiffeners close to an opening may be modelled using rod or beam elements located at a distance of at least 50 mm from the edge of the opening. Example of fine mesh around an opening is shown in [Figure 2](#).

2.2.3 Face plates

Face plates of openings, primary supporting members and associated brackets are to be modelled with at least two elements across their width on either side.

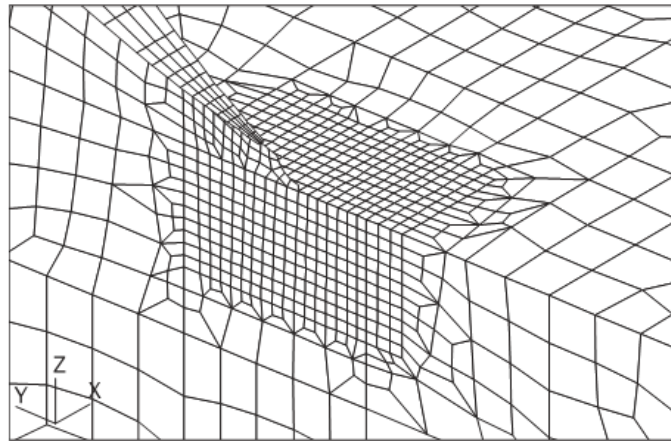
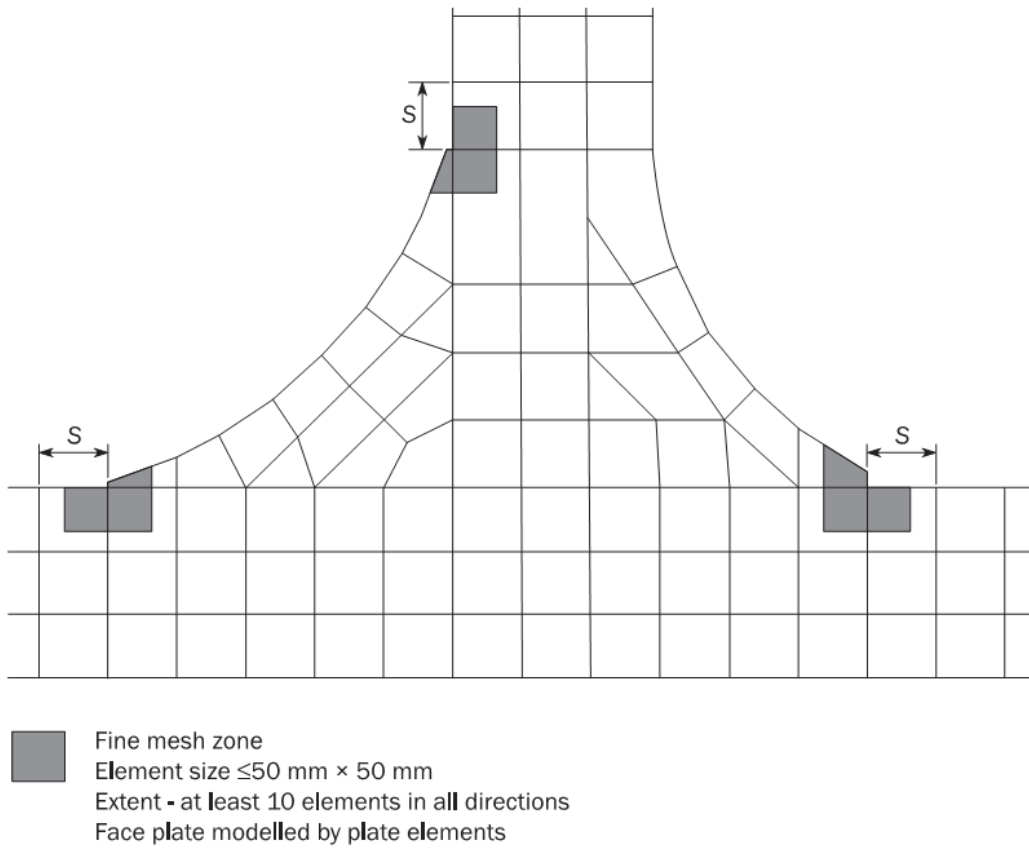

Figure 3 Fine mesh zone around bracket toes

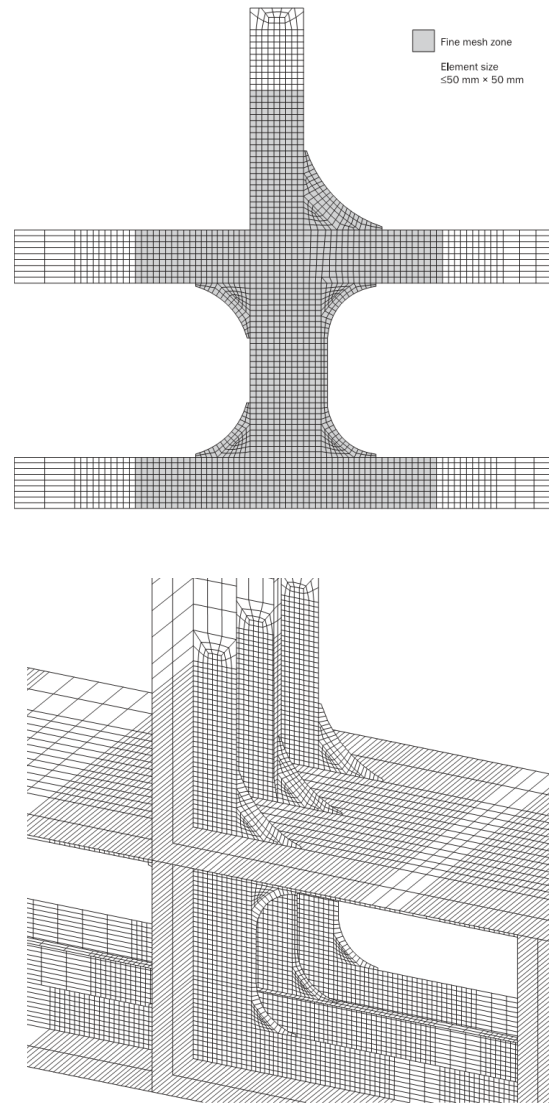

Figure 4 Example of local model for fine mesh analysis of end connections and web stiffeners of deck and double bottom longitudinals

2.3 FE model for fatigue strength assessments

If both fatigue and local strength assessment is required, a very fine mesh model ($t \times t$) for fatigue may be used in both analyses. In this case, the stresses for local strength assessment are to be weighted over an area equal to the specified mesh size $50 \text{ mm} \times 50 \text{ mm}$, as illustrated on [Figure 5](#). See also [\[5.2\]](#).

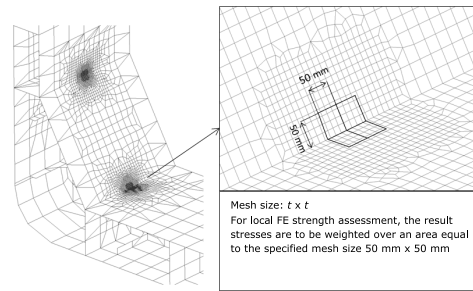

Figure 5 FE model of lower and upper hopper knuckles with mesh size $t \times t$ used for local fine mesh strength analysis

3 Screening

3.1 General

A screening analysis can be performed on the global or partial ship model to

- identify critical location for fine mesh analysis of a considered detail
- perform local strength assessment of similar details by calculating the relative stress level at different positions.

In partial ship analysis, the screening can be carried out in evaluation area only. The evaluation area is defined in [7].

3.2 Selection of structural detail for fine mesh analysis

The selection of required structural detail for fine mesh analysis is to be based on the screening results of the partial ship or global ship analysis. In general the location with the maximum yield utilisation factor, λ_y , in way of required structural detail, as required in the rules **RU SHIP Pt.5**, is to be selected for the fine mesh analysis.

Where the stiffener connection is required to be analysed, the selection is to be based on the maximum relative deflection between supports, i.e. between floor and transverse bulkhead or between deck transverse and transverse bulkhead. Where there is a significant variation in end connection arrangement between stiffeners or scantlings, analyses of connections may need to be carried out.

3.3 Screening based on fine mesh analysis

When fine mesh results are known for one location, the screening results can be used to perform local strength assessment of similar details, provided this details have similar geometry, comparable stress response and approximately the same mesh. This is done by combining the fine mesh results with screening results from the global or partial ship model.

A screening factor, K_{SC} , is calculated based on stress results from fine mesh analysis and corresponding global or partial ship analysis results, as follows:

$$K_{SC} = \frac{\sigma_{FM}}{\sigma_{CM}}$$

Where:

σ_{FM} = Von Mises fine mesh stress, in N/mm², for the considered detail
 σ_{CM} = Von Mises coarse mesh stress, in N/mm², for the considered detail

σ_{FM} and σ_{CM} are to be taken from the corresponding elements in the same plane position.

When the screening factor for a detail is found, the utilisation factor, λ_{SC} , for similar details can be calculated as follows:

$$\lambda_{SC} = \frac{K_{SC} \cdot \sigma_c}{R_y} \leq \lambda_{fperm}$$

Where:

σ_c = Von Mises coarse mesh stress, in N/mm², in way of considered detail.
 λ_{fperm} = Fine mesh permissible yield utilisation factor, see [5.3]

The utilisation factor, λ_{SC} , applies only where the detail is similar in its geometry, its proportion, and its relative location to the corresponding detail modelled in fine mesh for which K_{SC} factor is determined.

4 Loads and boundary conditions

4.1 Loads

The fine mesh detailed stress analysis is to be carried out for all FE load combinations applied to the corresponding partial ship or global FE analysis.

All local loads in way of the structure represented by the separate local finite element model are to be applied to the model.

4.2 Boundary conditions

Where a separate local model is used for the fine mesh detailed stress analysis, the nodal displacements from the cargo hold model are to be applied to the corresponding boundary nodes on the local model as prescribed displacements. Alternatively, equivalent nodal forces from the cargo hold model may be applied to the boundary nodes.

Where there are nodes on the local model boundaries which are not coincident with the nodal points on the cargo hold model, it is acceptable to impose prescribed displacements on these nodes using multi-point constraints.

5 Analysis criteria

5.1 Reference stress

Reference stress, σ_{vm} , is based on the membrane direct axial and shear stresses of the plate element evaluated at the element centroid. Where shell elements are used, the stresses are to be evaluated at the mid plane of the element. σ_{vm} is to be calculated in accordance to [7.2.1].

5.2 Permissible stress

The maximum permissible stresses are based on the mesh size of 50 mm × 50 mm, see [Figure 5](#). Where a smaller mesh size is used, an area weighted von Mises stress calculated over an area equal to the specified mesh size may be used to compare with the permissible stresses. The averaging is to be based only on elements with their entire boundary located within the desired area. The average stress is to be calculated based on stresses at element centroid; stress values obtained by interpolation and/or extrapolation are not to be used. Stress averaging is not to be carried across structural discontinuities and abutting structure.

5.3 Acceptance criteria - fine mesh permissible yield utilisation factors

The result from local structure strength analysis is to demonstrate that the von Mises stresses obtained from the FE analysis do not exceed the maximum permissible stress in fine mesh zone, as follows:

$$\lambda_f \leq \lambda_{fperm}$$

Where:

λ_f = Fine mesh yield utilisation factor.

$$\lambda_f = \frac{\sigma_{vm}}{R_Y} \quad \text{for plate elements in general}$$

$$\lambda_f = \frac{\sigma_{axial}}{R_Y} \quad \text{for rod elements in general}$$

σ_{vm} = Von Mises stress, in N/mm².

σ_{axial} = Axial stress in rod element, in N/mm².

λ_{fperm} = Permissible fine mesh utilisation factor, as given in the rules, [RU SHIP Pt.3 Ch.7 Sec.4 \[4\]](#)

R_Y = See [RU SHIP Pt.3 Ch.1 Sec.4 Table 3](#).

SECTION 5 BEAM ANALYSIS

1 Introduction

1.1 General

This section describes a linear static beam analysis of 2D and 3D frame structures. This provides with modelling methods and techniques required for a beam analysis in the Rules for Classification, Ships.

1.2 Application

1.2.1 General

A direct beam analysis in the Rules is addressed to complex grillage structures where the verification by means of single beam requirements or FE analysis is not used. The beam analysis applies for stiffeners and primary supporting members.

1.2.2 Strength assessment

Normally, the beam analysis is used to determine nominal stresses in the structure under the Rules defined loads and loading scenarios. The obtained stresses are used for verification of scantlings against yield criteria and for buckling check in girders. In case of bi-axial buckling assessment of plate flanges of primary supporting members, the stress transformation given in DNVGL-CG-0128 [3.2.2.7] applies.

In general, the beam analysis requirements are given in [RU SHIP Pt.3 Ch.6 Sec.5 \[1.2\]](#) for stiffeners and in [RU SHIP Pt.3 Ch.6 Sec.6 \[2\]](#) for PSM. For some specific structures the rule requirements are given also in other parts of [RU SHIP Pt.3, Pt.6](#) and CG's of specific ship types.

For the formulae given in this section, consistent units are assumed to be used. The actual units to be applied, however, may depend on the structural analysis program used in each case.

1.3 Model types

1.3.1 3D models

Three-dimensional models represent a part of the ship cargo such as hold structure of one or more cargo holds. See [Figure 11](#) and [Figure 12](#) for examples. The complex 3D models, however, should preferably be carried out as finite element models.

1.3.2 2D Models

Two-dimensional beam models, grillage or frame models, represent selected part of the ship such as:

- transverse frame structure which is calculated by a framework structure subjected to in plane loading, see [Figure 13](#) and [Figure 14](#) for examples,
- transverse bulkhead structure, which is modelled as a framework model subjected to in plane loading, see [Figure 17](#) and [Figure 18](#) for examples,
- double bottom structure, which is modelled as a grillage model, subjected to lateral loading, see [Figure 15](#) and [Figure 16](#) for examples.

In the 2D model analysis the boundary conditions may be used from the results of other 2D model in way of cut-off structure. For instance the bottom structure grillage model a) may utilize stiffness data and loads calculated by the transverse frame calculation and the transverse bulkhead calculation under a) and b) above. Alternatively, load and stiffness data may be based on approximate formulae or assumptions.

2 Model properties

2.1 General

2.1.1 Symbols

The symbols used in the model figures are described in [Figure 1](#).

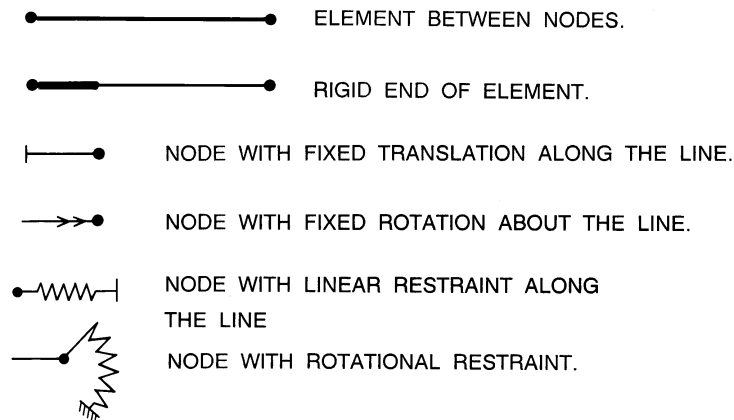

Figure 1 Symbols

2.2 Beam elements

2.2.1 Reference location of element

The reference location of element with well-defined cross-section (e.g. cross-ties in side tanks of tankers) is taken as the neutral axis for the element.

The reference location of member where the shell or bulkhead comprises one flange is taken as the line of intersection between the web plate and the plate flange.

In the case of double bottom floors and girders, cofferdam stringers etc. where both flanges are formed by plating, the reference location of each member is normally at half distance between plate flanges.

The reference location of bulkheads will have to be considered in each case and should be chosen in such a way that the overall behaviour of the model is satisfactory.

2.2.2 Corrosion addition

In general, beam analysis is to be carried out based on the corrosion additions (t_c) deducted from the offered scantlings according to the rules, [RU SHIP Pt.3 Ch.3 Sec.2 Table 1](#), unless otherwise is given in the rules for a specific structure. Typically the deductions will be $0.5 t_c$ for beam analysis (yield and buckling check) of primary supporting members (PSM) and t_c in case of beam analysis of local supporting members (stiffeners).

2.2.3 Variable cross-section or curved beams will normally have to be represented by a string of straight uniform beam elements.

For variable cross-section the number of subdivisions depends on the rate of change of the cross-section and the expected influence on the overall behaviour of the model.

For curved beam the lengths of the straight elements must be chosen in such a way that the curvature of the actual beam is represented in a satisfactory manner.

2.2.4 The increased stiffness of elements with bracketed ends is to be properly taken into account by the modelling. The rigid length to be used in the model, ℓ_r , may normally be taken as:

$$\ell_r = 0.5 h_o + k_h \text{ (see Figure 2)}$$

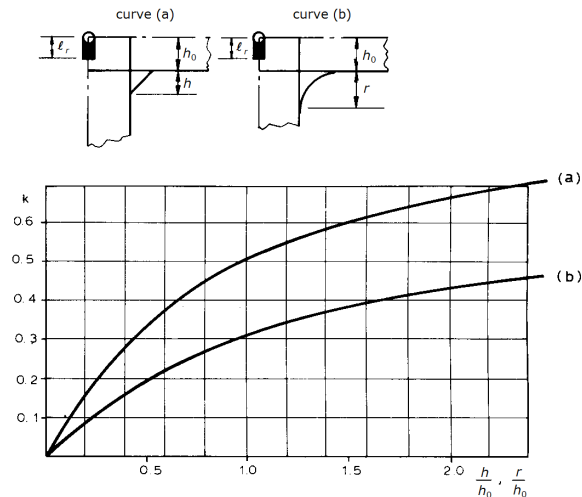

Figure 2 Rigid ends of beam elements

2.2.5 The additional girder bending flexibility associated with the shear deformation of girder webs in non-bracketed corners and corners with limited size softening brackets only should normally be included in the models as applicable.

The bilge region of transverse girders of open type bulk carriers and longitudinal double bottom girders supporting transverse bulkhead represent typical cases where the web shear deformation of the corner region may be of significance to the total girder bending response, see also Figure 3. The additional flexibility may be included in the model by introducing a rotational spring, K_{RC} , between the vertical bulkhead elements and the attached nodes in the double bottom, or alternatively by introducing beam elements of a short length, ℓ , and with cross-sectional moment of inertia, I , as given by the following expressions, see Figure 3:

$$K_{RC} = b_1 b_2 t G$$

$$I = \frac{b_1 b_2 t \ell G}{E}$$

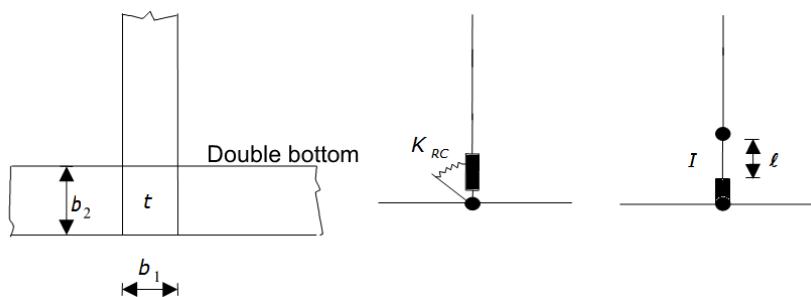

Figure 3 Non-bracketed corner model

2.2.6 Effective flange breadth

The effective breadth, b_{eff} , of the attached plating to stiffener or girder is to be considered in accordance with the rules [RU SHIP Pt.3 Ch.3 Sec.7 \[1.3\]](#).

Effective flange width of corrugations is to be applied according rules [RU SHIP Pt.3 Ch.6 Sec.4 \[1.2.4\]](#).

In case the longitudinal bulkheads and ship sides should be modelled as longitudinal beam elements to represent the hull girder bending and shear stiffness, for the analysis of internal structures, they may be considered as separate profiles. With reference to Figure A-4 (a) and (b) the equivalent flange widths of the longitudinal girder elements (L/bhd and ship side) may be taken as:

$$b_i = \frac{B}{2} \cdot \frac{x_i t_i^2}{\sum x_i t_i^2} \quad i=1,2,\dots$$

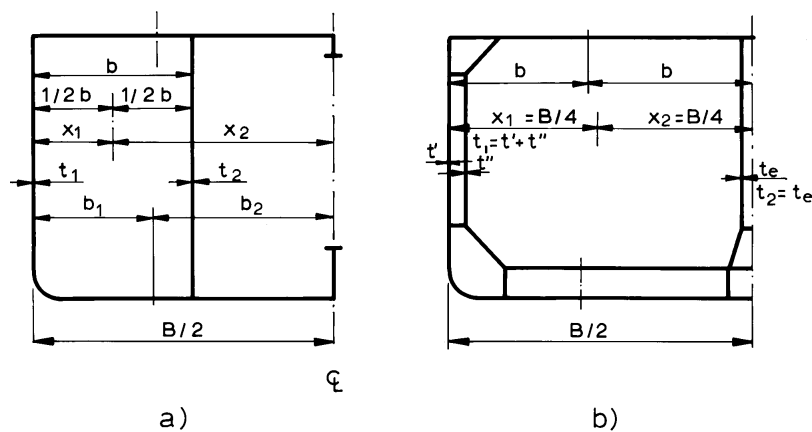

Figure 4 Hull girder sections

2.2.7 Equivalent thickness

For single skin girders with stiffeners parallel to the web, see [Figure 5](#), the equivalent flange thickness, t , is given by:

$$t = t_0 + 0.5 A_1/s$$

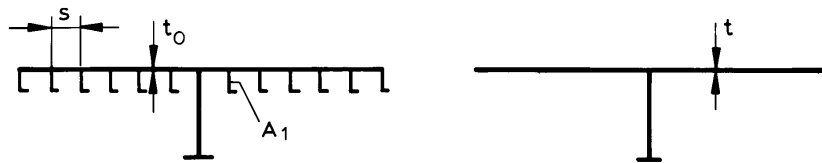

Figure 5 Equivalent flange thickness of single skin girder with stiffeners parallel to the web

2.2.8 Openings

Openings in girder's webs having influence on overall shear stiffness of a structure shall be included in the model. In way of such openings the web shear stiffness is to be reduced in beam elements. For normal arrangement of access and lightening holes a factor of 0.8 may be applied.

An extraordinary opening arrangement, e.g. with sequential openings, necessitates an investigation with a partial ship structural model and optionally with a local structural model.

2.2.9 Vertically corrugated bulkhead

When considering the overall stiffness of vertically corrugated bulkheads with stool tanks (transverse or longitudinal) subjected to in plane loading the elements should represent the shear and bending stiffnesses of the bulkhead and the torsional stiffness of the stool.

For corrugated bulkheads, due to the large shear flexibility of the upper corrugated part compared to the lower stool part, the bulkhead should be considered as split into two parts, here denoted the bulkhead part and the stool part, see also Figure 6.

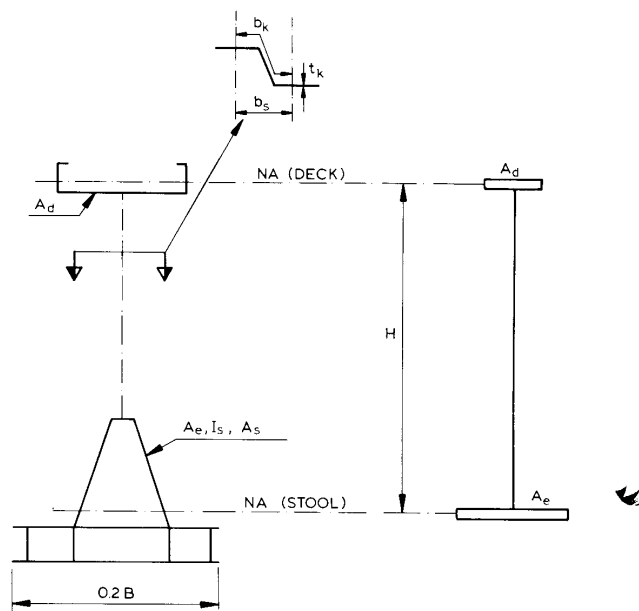

Figure 6 Cross-sectional data for bulkhead

For the corrugated bulkhead part, the cross-sectional moment of inertia, I_b , and the effective shear area A_b may be calculated as follows:

$$I_b = H^2 \frac{A_d A_e}{A_d + A_e}$$

$$A_b = t_k H \frac{b_s}{b_k}$$

Where:

A_d = cross-sectional area of deck part

- A_e = cross-sectional area of stool and bottom part
 H = distance between neutral axis of deck part and stool and bottom part
 t_k = thickness of bulkhead corrugation
 b_s = breadth of corrugation
 b_k = breadth of corrugation along the corrugation profile

For the stool and bottom part, the cross-sectional properties, moment of inertia I_s and shear area A_s , should be calculated as normal. Based on the above a factor, K , may be determined by the formula:

$$K = 1 + \frac{I_s \left(1 + \frac{100I_b}{A_b B^2} \right)}{I_b \left(\frac{1 + 100I_s}{A_s B^2} \right)}$$

Applying this factor, the cross-sectional properties of the transverse bulkhead members moment of inertia I and effective shear area A as a whole may be calculated according to:

$$I = KI_b$$

$$A = KA_b$$

which should be applied in the double bottom calculation.

2.2.10 Torsion box

In beam models the torsional stiffness of box structures is normally represented by beam element torsional stiffness, and in case of three-dimensional modelling sometimes by shear elements representing the various panels constituting the box structure. Typical examples where shear elements have been used are shown in [Figure 11](#), while a conventional beam element torsional stiffness has been applied in [Figure 12](#).

The torsional moment of inertia, I_T , of a torsion box may generally be determined according to the following formula:

$$I_t = \frac{\left(\sum_{i=1}^{i=n} r_i s_i \right)^2}{\left(\sum_{i=1}^{i=n} \frac{s_i}{t_i} \right)}$$

Where:

- n = no. of panels of which the torsion box is composed

- t_i = thickness of panel no. i
 s_i = breadth of panel no. i
 r_i = distance from panel no. i to the centre of rotation for the torsion box. Note the centre of rotation must be determined with due regard to the restraining effect of major supporting panels (such as ship side and double bottom) of the box structure.

Examples with thickness and breadths definitions are shown on [Figure 9](#) for stool structure and on [Figure 10](#) for hopper structure.

2.3 Springs

2.3.1 General

In simplified two-dimensional modelling, three-dimensional effects caused by supporting girders may normally be represented by springs. The effect of supporting torsion boxes may be normally represented by rotational springs or by axial springs representing the stiffness of the various panels of the box.

2.3.2 Linear springs

General formula for linear spring stiffness, k , is given as:

$$k = \frac{P}{\delta}$$

Where:

- P = Force
 δ = Deflection

The calculation of the springs in different cases of support and loads is shown in [Table 1](#).

2.3.3 Rotational springs

General formula for rotational spring stiffness, k_r , is given as:

$$k_r = \frac{M}{\theta}$$

Where:

- M = Moment
 θ = Rotation

- a) Springs representing the stiffness of adjoining girders. With reference to [Figure 7](#) and [Figure 8](#) the rotational spring may be calculated using the following formula:

$$k_r = \frac{E}{\frac{\ell \Psi}{s \ell} + \frac{2.6 \beta}{\ell A_s} + \frac{E}{k \ell^2}}$$

- $s = 3$ for pinned end connection
 $= 4$ for fixed end connection

- b) Springs representing the torsional stiffness of box structures. Such springs may be calculated using the following formula:

$$k_r = \frac{8cGI_t}{l}$$

Where:

$$c = \frac{n+1}{n(n+2)}$$

when $n =$ even number.

$$= \frac{1}{n+1}$$

when $n =$ odd number.

$l =$ length between fixed box ends.

$n =$ number of loads along the box.

$I_t =$ torsional moment of inertia of the box which may be calculated as given in [\[2.2.10\]](#)

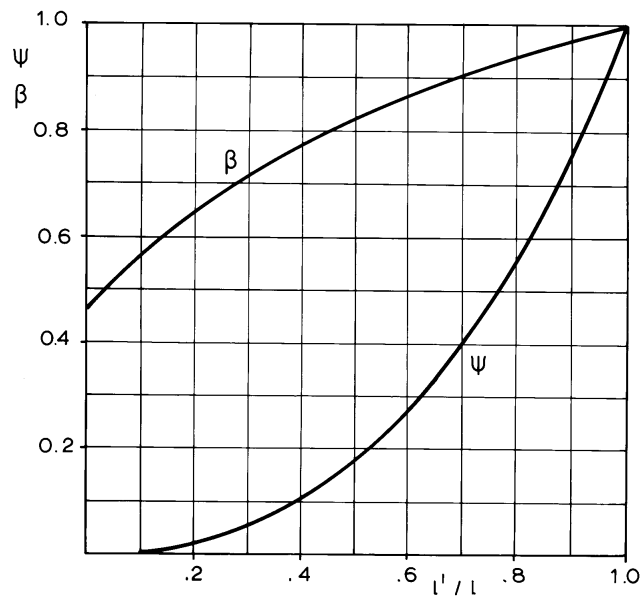

Figure 7 Determination of spring stiffness

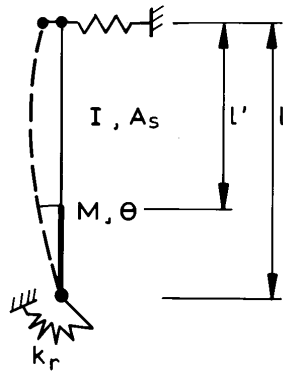

Figure 8 Effective length, l'

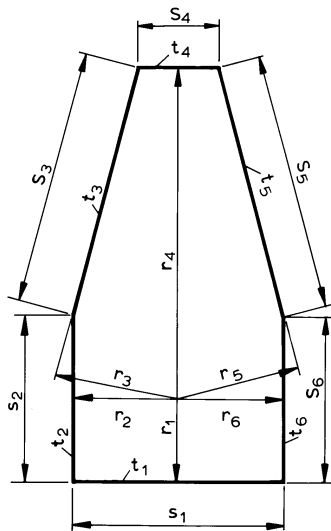

Figure 9 Definition of thickness and breadths for stool tank structure

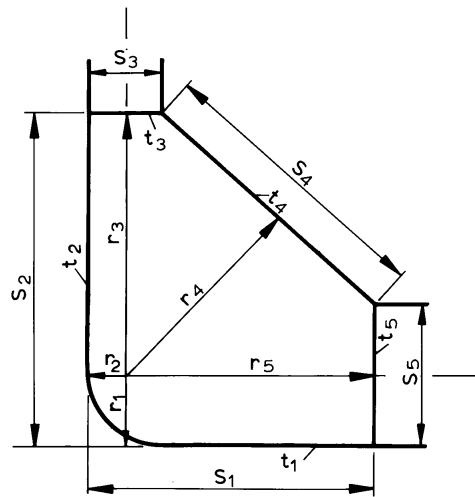

Figure 10 Definition of thickness and breadths for hopper tank structure

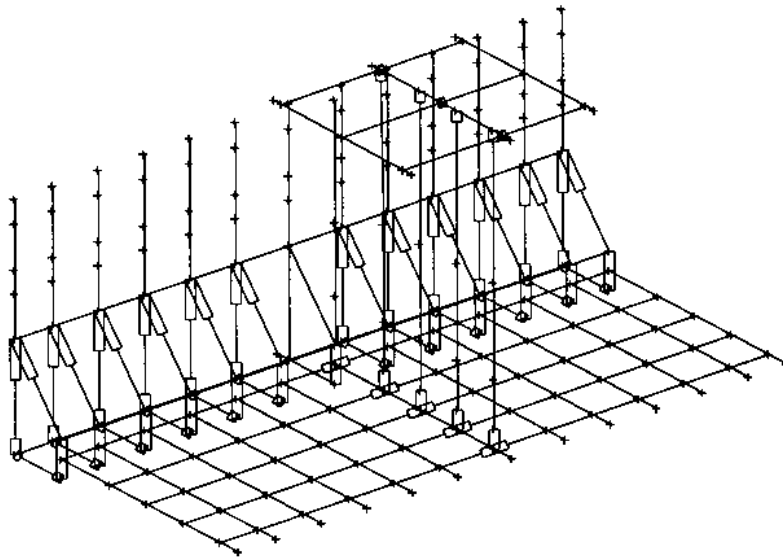

Figure 11 3D beam element model covering double bottom structure, hopper region represented by shear panels, bulkhead and deck between hatch structure. The main frames are lumped.

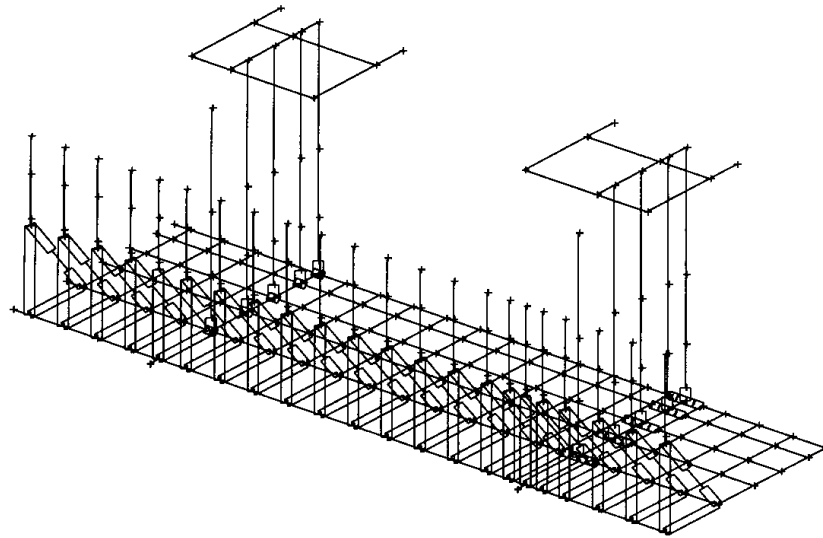
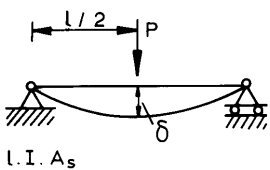
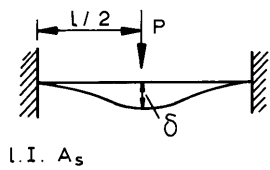
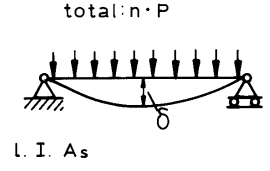
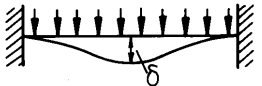
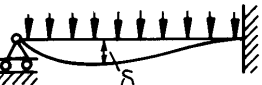
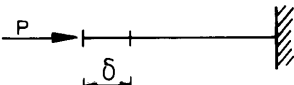

Figure 12 3D beam element model covering double bottom structure, hopper region, bulkhead and deck between holds. The main frames are lumped.

Table 1 Spring stiffness for different boundary conditions and loads

Type	Deflection δ	Spring stiffness $k = P/\delta$
 <p style="text-align: center;">I. I. A_s</p>	$\delta = \frac{P l^3}{48 E I} + \frac{P l}{4 A_s G}$	$k = \frac{E}{\frac{l^3}{48 I} + \frac{2.6 l}{4 A_s}}$
 <p style="text-align: center;">I. I. A_s</p>	$\delta = \frac{P l^3}{192 E I} + \frac{P l}{4 A_s G}$	$k = \frac{E}{\frac{l^3}{192 I} + \frac{2.6 l}{4 A_s}}$
 <p style="text-align: center;">total: $n \cdot P$</p> <p style="text-align: center;">I. I. A_s</p>	$\delta = \frac{5 P n (n+2) l^3}{384 E I (n+1)} + \frac{P (n+1) l}{8 A_s G}$	$k = \frac{E}{\frac{5 n (n+2) l^3}{384 I (n+1)} + \frac{2.6 (n+1) l}{8 A_s}}$

Type	Deflection δ	Spring stiffness $k = P/\delta$
<p>total: $n \cdot P$</p>  <p>L. I. A_s</p>	$\delta = \frac{P(n+1)l^3}{384EI} + \frac{P(n+1)l}{8A_s G}$	$k = \frac{E}{\frac{(n+1)l^3}{384I} + \frac{2.6(n+1)l}{8A_s}}$
<p>total: $n \cdot P$</p>  <p>L. I. A_s</p>	$\delta = \frac{P(n+1)l^3}{185EI} + \frac{P(n+1)l}{8A_s G}$	$k = \frac{E}{\frac{(n+1)l^3}{185I} + \frac{2.6(n+1)l}{8A_s}}$
 <p>L. A</p>	$\delta = \frac{Pl}{AE}$	$k = \frac{E}{\left(\frac{l}{A}\right)}$

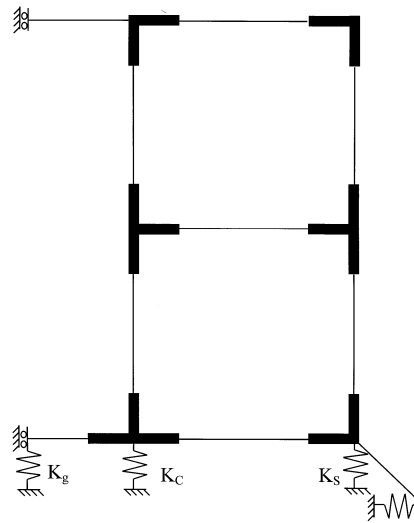

Figure 13 Transverse frame model of a ship with two longitudinal bulkhead

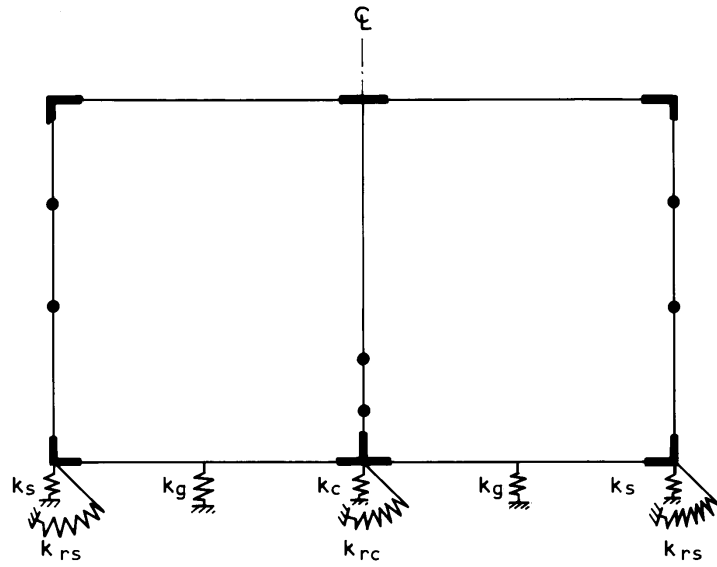

Figure 14 Transverse frame model of a ship with one longitudinal bulkhead

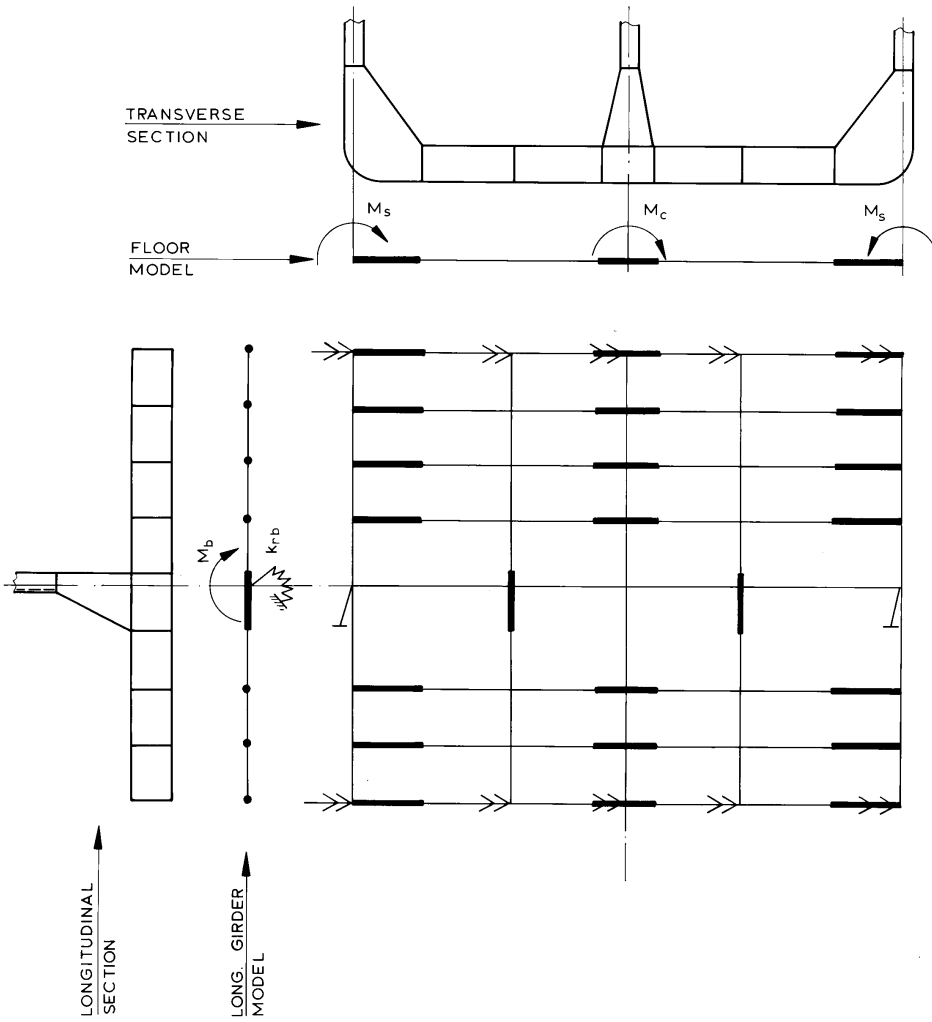

Figure 15 Bottom grillage model of a ship with one longitudinal bulkhead

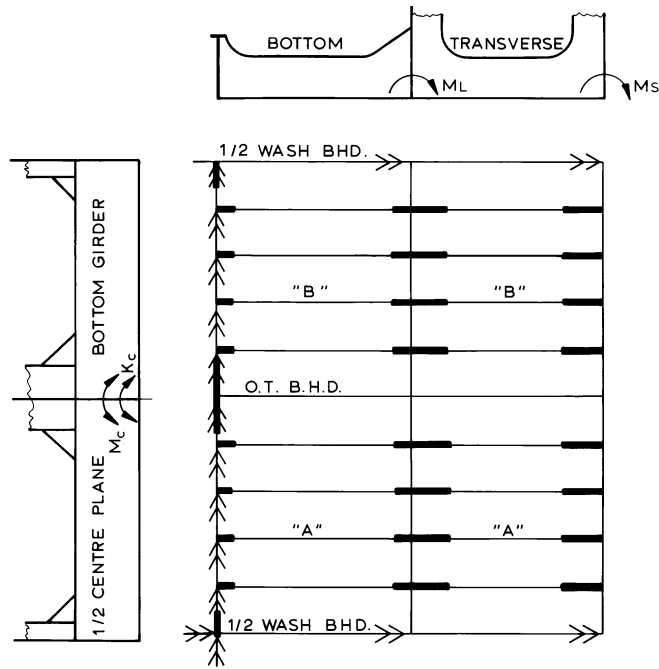

Figure 16 Bottom grillage model of a ship with two longitudinal bulkheads

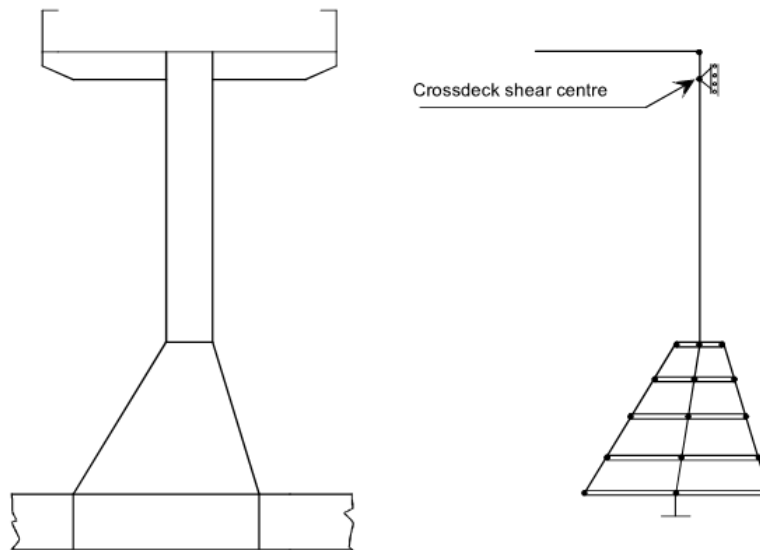

Figure 17 Two-dimensional beam model of vertical corrugated bulkhead (see also Figure A-19)

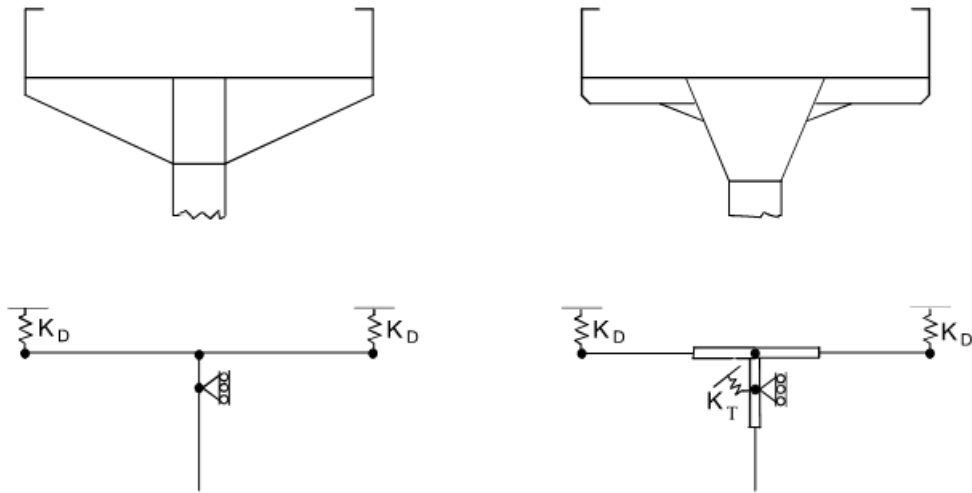

Figure 18 Spring support by hatch end coamings

DNV GL

Driven by our purpose of safeguarding life, property and the environment, DNV GL enables organizations to advance the safety and sustainability of their business. We provide classification and technical assurance along with software and independent expert advisory services to the maritime, oil and gas, and energy industries. We also provide certification services to customers across a wide range of industries. Operating in more than 100 countries, our 16 000 professionals are dedicated to helping our customers make the world safer, smarter and greener.

SAFER, SMARTER, GREENER